

# POWER QUALITY

## Energy Efficiency Reference Guide

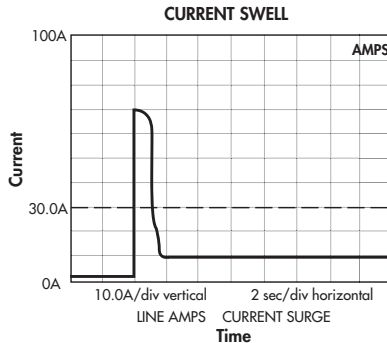

DISCLAIMER: BC Hydro, CEA Technologies Inc., Consolidated Edison, Hydro One, Hydro-Québec, Manitoba Hydro, Natural Resources Canada, Ontario Power Authority, Sask Power, Southern Company, Energy @ Work or any other person acting on their behalf will not assume any liability arising from the use of, or damages resulting from the use of any information, equipment, product, method or process disclosed in this guide.

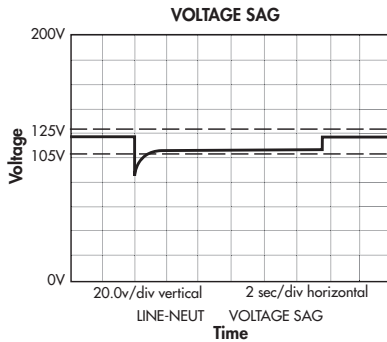

It is recommended to use certified practitioners for the applications of the directives and recommendations contained herein.

Technical Editing and Power Quality Subject Expert:  
 Brad Gibson P.Eng., Cohos Evamy Partners, Calgary, AB  
 Mr. Scott Rouse, P.Eng., MBA, CEM, Energy @ Work,  
[www.energy-efficiency.com](http://www.energy-efficiency.com)

Portions of this Guide have been reproduced with the permission of Ontario Power Generation Inc. All Rights Reserved.

# TABLE OF CONTENTS

---

Page	Section
10	Acknowledgements
11	Foreword
11	Power Quality Guide Format
14	1.0 The Scope of Power Quality
14	1.1 Definition of Power Quality
15	1.2 Voltage
15	1.2.1 Voltage Limits
18	1.3 Why Knowledge of Power Quality is Important
19	1.4 Major Factors Contributing to Power Quality Issues
20	1.5 Supply vs. End Use Issues
21	1.6 Countering the Top 5 PQ Myths
21	1) Old Guidelines are NOT the Best Guidelines
21	2) Power Factor Correction DOES NOT Solve all Power Quality Problems
22	3) Small Neutral to Ground Voltages DO NOT Indicate a Power Quality Problem
23	4) Low Earth Resistance is NOT MANDATORY for Electronic Devices

23	5) Uninterruptible Power Supplies (UPS) DO NOT Provide Complete Power Quality Protection	42	3.4.1 Transients, Short Duration and Long Duration Variations
24	1.7 Financial and Life Cycle Costs	49	3.4.2 Steady State Disturbances
25	1.7.1 Simple Payback	49	3.4.2.1 Waveform Distortion and Harmonics
26	1.7.2 Life Cycle Costing	59	3.4.2.2 Flicker
26	1.7.3 The Cost of Power Quality Problem Prevention	59	3.4.3 Distribution and Wiring Problems
		60	3.4.3.1 Fault Protection in Utility Distribution Systems
28	<b>2.0 Understanding Power Quality Concepts</b>	64	3.4.4 Voltage Unbalance
28	2.1 The Electrical Distribution System	64	3.5 Relative Frequency of Occurrence
29	2.1.1 Voltage Levels and Configurations	67	3.6 Related Topics
30	2.1.2 Site Distribution	67	3.6.1 Electromagnetic Compatibility (EMC)
32	2.2 Basic Power Quality Concepts	68	3.7 Three Power Quality Case Studies
32	2.2.1 Grounding and Bonding	68	3.7.1 <b>Case Study:</b> Meter, Monitor & Manage: A proactive response to power quality
36	<b>3.0 Power Quality Problems</b>	71	3.7.2 <b>Case Study:</b> High Demand Load in an Aircraft Assembly Facility
36	3.1 How Power Quality Problems Develop	72	3.7.3 <b>Case Study:</b> Motor Drive and Transformer Incompatibility in a Commercial Building
38	3.2 Power Quality Disturbances		
39	3.3 Load Sensitivity: Electrical Loads that are affected by Poor Power Quality	75	<b>4.0 Solving and Mitigating Electrical Power Problems</b>
39	3.3.1 Digital Electronics	75	4.1 Identifying the root cause and assessing symptoms
41	3.3.2 Lighting		
42	3.3.3 Motors		
42	3.4 Types and Sources of Power Quality Problems		

<b>76</b>	4.2 Improving site conditions	<b>97</b>	Mitigating Equipment
<b>76</b>	4.2.1 Mitigating Effects	<b>98</b>	Equipment Ratings
<b>76</b>	4.2.2 Mitigating Equipment	<b>99</b>	Best Practices
<b>77</b>	4.2.1.1 Dedicated Circuits	<b>99</b>	4.3.2 Troubleshooting
<b>77</b>	4.2.1.2 Surge Protective Devices (SPDs; also known as Transient Voltage Surge Suppressors, TVSS)	<b>101</b>	<b>5.0 Where to Go for Help</b>
<b>78</b>	4.2.1.3 Lightning Arresters	<b>101</b>	<b>Web Resources</b>
<b>78</b>	4.2.1.4 End-User SPDs	<b>102</b>	<b>CSA Relevant Standards</b>
<b>80</b>	4.2.1.5 Power Line Filters		
<b>82</b>	4.2.1.6 Isolation Transformers		
<b>84</b>	4.2.1.7 Line Voltage Regulators		
<b>85</b>	4.2.1.8 Ferroresonant Transformers		
<b>86</b>	4.2.1.9 Tap Switching Transformers		
<b>86</b>	4.2.1.10 Power Conditioners		
<b>87</b>	4.2.1.11 UPS Systems		
<b>89</b>	4.2.1.12 Isolated Grounding Outlets		
<b>90</b>	4.2.3 Preventative Measures		
<b>90</b>	4.2.3.1 Distribution System Considerations for Sensitive Loads		
<b>93</b>	4.2.4 High Frequency Grounding Considerations		
<b>96</b>	4.3 Troubleshooting and Predictive Tips		
<b>96</b>	4.3.1 Tips		
<b>96</b>	Distribution Wiring and Grounding		

# Table of Figures

---

- 15 Figure 1: Pure Sinusoidal AC Voltage Waveform
- 17 Figure 2: RMS Voltage and Current Produced When Starting a Motor
- 28 Figure 3: Electrical Transmission and Distribution
- 29 Figure 4: 120/240 V Single-phase Service
- 29 Figure 5: Typical 208 V Three-phase Wye Connected Service
- 30 Figure 6: Grounded Wye Connection
- 31 Figure 7: Typical Residential Service
- 31 Figure 8: Service with Branch Panel Boards
- 32 Figure 9: Typical Transformer Installation
- 34 Figure 10: Equipment Without Proper Equipment Bonding
- 34 Figure 11: Equipment With Proper Equipment Bonding
- 36 Figure 12: Elements of a Power Quality Problem
- 40 Figure 13: Computer Susceptibility Profile to Line Voltage Variations and Disturbances – The ITIC Curve
- 50 Figure 14: Superposition of Harmonic on Fundamental: Initially In-Phase
- 51 Figure 15: Superposition of Harmonic on Fundamental: Initially Out-of-Phase
- 52 Figure 16: Main Sources of Harmonics
- 53 Figure 17: Harmonics Produced by Three-Phase Controlled Loads
- 55 Figure 18: Harmonic Effects on Equipment
- 59 Figure 19: Flicker Curve IEEE 519-1992
- 61 Figure 20: Example of a Repetitive Reclosure Operation
- 62 Figure 21: Effect of Multiple Reclosure Operation on Voltage
- 63 Figure 22: Reclosing Interval for Hydraulic and Electrical Control Types
- 65 Figure 23: Relative Occurrence of Disturbances to Power Systems Supplying Computers
- 67 Figure 24: Individual Voltage Harmonic Statistics 222 EPRI DPQ Sites from 6/1/93 to 6/1/94
- 79 Figure 25: Effect of Line Clamp on Transient Voltages, 120 Volt System
- 79 Figure 26: Example of Impulses Not Clamped
- 81 Figure 27: Examples of Untuned Filters
- 90 Figure 28: Motor and Sensitive Loads Supplied from the Same Feeder
- 92 Figure 29: Motor and Computer Loads Supplied from Separate Feeder
- 92 Figure 30: Isolation Transformer Added to Computer Feeder Supply
- 94 Figure 31: Equivalent Circuit of a Wire
- 95 Figure 32: Signal Reference Structure or “Grid”

## Acknowledgements

This guide was prepared for the CEA Technologies Inc. Customer Energy Solutions Interest group (CESIG) with the sponsorship of the following utility consortium participants:

BC Hydro Power Smart	BC	Canada
Consolidated Edison Company of New York	NY	USA
Hydro One Networks	ON	Canada
Hydro-Québec	QC	Canada
Manitoba Hydro	MB	Canada
Natural Resources Canada		Canada
Ontario Power Authority	ON	Canada
Sask Power	SK	Canada
Southern Company	AL	USA

Energy@Work is grateful to CEATI for the opportunity to work on this interesting issue. The support and guidance by the CEATI CESIG Technology Coordinator, Phil Elliott, and Program Manager, Angelo Giumento, was greatly appreciated by the investigators.

Scott Rouse and Brad Gibson wish to express their gratitude for the support and contribution of ideas of project monitors: Cristiana Dimitriu from Consolidated Edison, Masoud Almassi from Hydro-One, Jean Bertin-Mahieux from Hydro-Québec, Rob Kolt & Mike Kizuik from Manitoba Hydro and Norm Benoit from Natural Resources Canada.

## Foreword

### Power Quality Guide Format

Power quality has become the term used to describe a wide range of electrical power measurement and operational issues. Organizations have become concerned with the importance of power quality because of potential safety, operational and economic impacts.

Power quality is also a complex subject requiring specific terminology in order to properly describe situations and issues. Understanding and solving problems becomes possible with the correct information and interpretation.

This Power Quality Reference Guide is written to be a useful and practical guide to assist end-use customers and is structured in the following sections:

#### Section 1: Scope of Power Quality

Provides an understanding that will help to de-mystify power quality issues

#### Section 2: Understanding Power Quality Concepts

Defines power quality, and provides concepts and case study examples

#### Section 3: Power Quality Problems

Helps to understand how power quality problems develop

## Section 4: Solving and Mitigating Electrical Power Problems

Suggestions and advice on potential power quality issues

## Section 5: Where to go for Help

Power quality issues are often addressed reactively. Planned maintenance is more predictable and cost effective than unplanned, or reactive, maintenance if the right information is available. Power quality problems often go unnoticed, but can be avoided with regular planned maintenance and the right mitigating technologies.

Prevention is becoming more accepted as companies, particularly those with sensitive equipment, are recognizing that metering, monitoring and management is an effective strategy to avoid unpleasant surprises. Metering technology has also improved and become cost effective in understanding issues and avoiding problems.

Selecting the proper solution is best achieved by asking the right question up front. In the field of power quality, that question might best be addressed as:

**“What level of power quality is required for my electrical system to operate in a satisfactory manner, given proper care and maintenance?”**

**NOTE:** It is strongly recommended that individuals or companies undertaking comprehensive power quality projects secure the services of a professional specialist qualified in power quality in order to understand and maximize the available benefits. Project managers on power quality projects often undervalue the importance of obtaining the correct data, analysis and up-front engineering that is necessary to thoroughly understand the root cause of the problems. Knowing the problem and reviewing options will help secure the best solution for the maximum return on investment (ROI).

# 1.0 The Scope of Power Quality

## 1.1 Definition of Power Quality

The Institute of Electrical and Electronic Engineers (IEEE) defines power quality as:

*“The concept of powering and grounding electronic equipment in a manner that is suitable to the operation of that equipment and compatible with the premise wiring system and other connected equipment.”<sup>1</sup>*

Making sure that power and equipment are suitable for each other also means that there must be compatibility between the electrical system and the equipment it powers. There should also be compatibility between devices that share the electrical distribution space. This concept is called Electromagnetic Compatibility (“EMC”) and is defined as:

*“the ability of an equipment or system to function satisfactorily in its electromagnetic environment without introducing intolerable electromagnetic disturbances to anything in that environment.”<sup>2</sup>*

The best measure of power quality is the ability of electrical equipment to operate in a satisfactory manner, given proper care and maintenance and without adversely affecting the operation of other electrical equipment connected to the system.

## 1.2 Voltage

The voltage produced by utility electricity generators has a sinusoidal waveform with a frequency of 60 Hz in North America and 50 Hz in many other parts of the world. This frequency is called the fundamental frequency.

**Figure 1: Pure Sinusoidal AC Voltage Waveform**

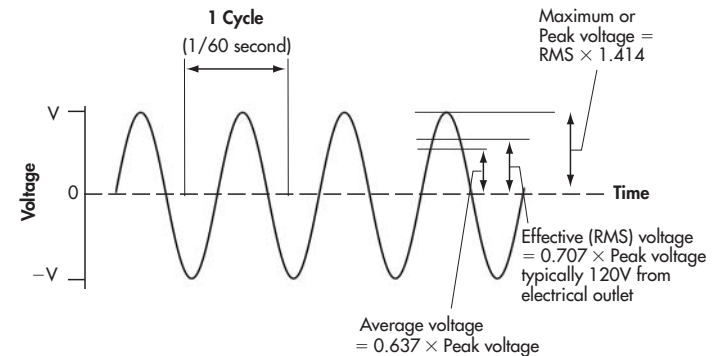

Any variation to the voltage waveform, in magnitude or in frequency, is called a power line deviation. However, not all power line deviations result in disturbances that can cause problems with the operation of electrical equipment.

### 1.2.1 Voltage Limits

Excessive or reduced voltage can cause wear or damage to an electrical device. In order to provide standardization, recommended voltage variation limits at service entrance points are specified by the electrical distributor or local utility. An example of typical voltage limits is shown in the table below.

<sup>1</sup>IEEE-Std 1100-1999, IEEE Recommended Practice for Powering and Grounding Electronic Equipment, New York, IEEE, 1999

<sup>2</sup>A definition from the IEC at <http://www.iec.ch/zone/emc/whatis.htm>

Rated voltage (V)*	Voltage limits at point of delivery			
	Marginal operating conditions			
	Normal operating conditions			
Single-phase circuits 120/240 480 600	106/212 424 530	110/220 440 550	125/250 500 625	127/254 508 635
Three-phase/ four-wire circuits 120/208 (Y)* 277/480(Y) 347/600 (Y)	110/190 245/424 306/530	112/194 254/440 318/550	125/216 288/500 360/625	127/220 293/508 367/635
Three-phase/ three-wire circuits 240 480 600	212 424 530	220 440 550	250 500 625	254 508 635
Medium-voltage circuits 1,000–50,000	- 6%	- 6%	+ 6%	+ 6%

In addition to system limits, Electrical Codes specify voltage drop constraints; for instance:

- (1) The voltage drop in an installation shall:
  - be based upon the calculated demand load of the feeder or branch circuit.
  - not exceed 5% from the supply side of the consumer’s service (or equivalent) to the point of utilization.
  - not exceed 3% in a feeder or branch circuit.
- (2) The demand load on a branch circuit shall be the connected load, if known, otherwise 80% of the rating of the overload or over-current devices protecting the branch circuit, whichever is smaller.<sup>3</sup>

For voltages between 1000 V and 50 000 V, the maximum allowable variation is typically ±6% at the service entrance.

<sup>3</sup> Check with your local Authority Having Jurisdiction for rules in your area.

There are no comparable limits for the utilization point. These voltage ranges exclude fault and temporary heavy load conditions. An example of a temporary heavy load condition is the startup of a motor. Since motors draw more current when they start than when they are running at their operating speed, a voltage sag may be produced during the initial startup.

**Figure 2: RMS Voltage and Current Produced when Starting a Motor**

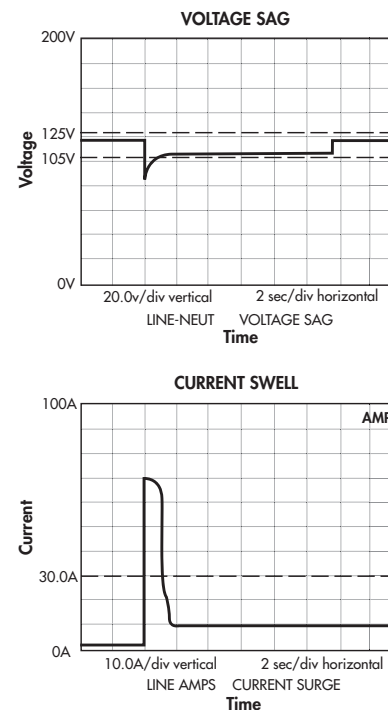

(Reproduced with Permission of Basic Measuring Instruments, from “Handbook of Power Signatures”, A. McEachern, 1988)

It is not technically feasible for a utility to deliver power that is free of disturbances at all times. If a disturbance-free voltage waveform is required for the proper operation of an electrical product, mitigation techniques should be employed at the point of utilization.

### 1.3 Why Knowledge of Power Quality is Important

Owning or managing a concentration of electronic, control or life-safety devices requires a familiarity with the importance of electrical power quality.

Power quality difficulties can produce significant problems in situations that include:

- important business applications (banking, inventory control, process control)
- critical industrial processes (programmable process controls, safety systems, monitoring devices)
- essential public services (paramedics, hospitals, police, air traffic control)

Power quality problems in an electrical system can also quite frequently be indicative of safety issues that may need immediate corrective action. This is especially true in the case of wiring, grounding and bonding errors.

Your electrical load should be designed to be compatible with your electrical system. Performance measures and operating guidelines for electrical equipment compatibility are available from professional standards, regulatory agency policies and utility procedures.

### 1.4 Major Factors Contributing to Power Quality Issues

The three major factors contributing to the problems associated with power quality are:

#### Use of Sensitive Electronic Loads

The electric utility system is designed to provide reliable, efficient, bulk power that is suitable for the very large majority of electrical equipment. However, devices like computers and digital controllers have been widely adopted by electrical end-users. Some of these devices can be susceptible to power line disturbances or interactions with other nearby equipment

#### The Proximity of Disturbance-Producing Equipment

Higher power loads that produce disturbances – equipment using solid state switching semiconductors, arc furnaces, welders and electric variable speed drives – may cause local power quality problems for sensitive loads.

#### Source of Supply

Increasing energy costs, price volatility and electricity related reliability issues are expected to continue for the foreseeable future. Businesses, institutions and consumers are becoming more demanding and expect a more reliable and robust electrical supply, particularly with the installation of diverse electrical devices. Compatibility issues may become more complex as new energy sources and programs, which may be sources of power quality problems, become part of the supply solution. These include distributed generation, renewable energy solutions, and demand response programs

Utilities are regulated and responsible for the delivery of energy to the service entrance, i.e., the utility meter. The

supply must be within published and approved tolerances as approved by the regulator. Power quality issues on the “customer side of the meter” are the responsibility of the customer. It is important therefore, to understand the source of power quality problems, and then address viable solutions.

## 1.5 Supply vs. End Use Issues

Many studies and surveys have attempted to define the percentage of power quality problems that occur as a result of anomalies inside a facility and how many are due to problems that arise on the utility grid. While the numbers do not always agree, the preponderance of data suggests that most power quality issues originate within a facility; however, there can be an interactive effect between facilities on the system.

Does this matter? After all, 100% of the issues that can cause power quality problems in your facility will cause problems no matter where they originate. If the majority of power quality issues can be controlled in your own facility, then most issues can be addressed at lower cost and with greater certainty. Understanding how your key operational processes can be protected will lead to cost savings.

Utilities base their operational quality on the number of minutes of uninterrupted service that are delivered to a customer. The requirements are specific, public and approved by the regulator as part of their rate application (often referred to as the ‘Distributors Handbook’).

While some issues affecting the reliability of the utility grid – such as lightning or animal caused outages – do lead to power quality problems at a customer’s facilities, the utility cannot control these problems with 100% certainty. Utilities can provide guidance to end users with power quality

problems but ultimately these key principles apply:

- **Most PQ issues are end-user issues**
- **Most supply issues are related to utility reliability**

## 1.6 Countering the Top 5 PQ Myths

1) Old Guidelines are NOT the Best Guidelines

Guidelines like the Computer Business Equipment Manufacturers Association Curve (CBEMA, now called the ITIC Curve) and the Federal Information Processing Standards Pub94 (FIPS Pub94) are still frequently cited as being modern power quality guidelines.

The ITIC curve is a generic guideline for characterizing how electronic loads typically respond to power disturbances, while FIPS Pub94 was a standard for powering large main-frame computers.

Contrary to popular belief, the ITIC curve is not used by equipment or power supply designers, and was actually never intended for design purposes. As for the FIPS Pub94, it was last released in 1983, was never revised, and ultimately was withdrawn as a U.S. government standards publication in November 1997. While some of the information in FIPS Pub94 is still relevant, most of it is not and should therefore not be referenced without expert assistance.

2) Power Factor Correction DOES NOT Solve all Power Quality Problems

Power factor correction reduces utility demand charges for apparent power (measured as kVA, when it is metered) and lowers magnetizing current to the service entrance. It is not directly related to the solution of power quality problems.

There are however many cases where improperly maintained capacitor banks, old PF correction schemes or poorly designed units have caused significant power quality interactions in buildings.

The best advice for power factor correction is the same as the advice for solving power quality issues; properly understand your problem first. A common solution to power factor problems is to install capacitors; however, the optimum solution can only be found when the root causes for the power factor problems are properly diagnosed. Simply installing capacitors can often magnify problems or introduce new power quality problems to a facility.

Power factor correction is an important part of reducing electrical costs and assisting the utility in providing a more efficient electrical system. If power factor correction is not well designed and maintained, other power quality problems may occur. The electrical system of any facility is not static. Proper monitoring and compatible design will lead to peak efficiency and good power quality.

### 3) Small Neutral to Ground Voltages DO NOT Indicate a Power Quality Problem

Some people confuse the term “common mode noise” with the measurement of a voltage between the neutral and ground wires of their power plug. A small voltage between neutral to ground on a working circuit indicates normal impedance in the wire carrying the neutral current back to the source. In most situations, passive “line isolation” devices and “line conditioners” are not necessary to deal with Neutral to Ground voltages.

### 4) Low Earth Resistance is NOT MANDATORY for Electronic Devices

Many control and measurement device manufacturers recommend independent or isolated grounding rods or systems in order to provide a “low reference earth resistance”. Such recommendations are often contrary to Electrical Codes and do not make operational sense. Bear in mind that a solid connection to earth is not needed for advanced avionics or nautical electronics!

### 5) Uninterruptible Power Supplies (UPS) DO NOT Provide Complete Power Quality Protection

Not all UPS technologies are the same and not all UPS technologies provide the same level of power quality protection. In fact, many lower priced UPS systems do not provide any power quality improvement or conditioning at all; they are merely back-up power devices. If you require power quality protection like voltage regulation or surge protection from your UPS, then make sure that the technology is built in to the device.

## 1.7 Financial and Life Cycle Costs

The financial and life cycle costs of power quality issues are two fold;

1. **The “hidden cost” of poor power quality.** The financial impact of power quality problems is often underestimated or poorly understood because the issues are often reported as maintenance issues or equipment failures. The true economic impact is often not evaluated.
2. **The mitigation cost or cost of corrective action to fix the power quality issue.** The costs associated with solving or reducing power quality problems can vary from the inexpensive (i.e., checking for loose wiring connections), to the expensive, such as purchasing and installing a large uninterruptible power supply (UPS).

24

Evaluation of both costs should be included in the decision process to properly assess the value, risk and liquidity of the investment equally with other investments. Organizations use basic financial analysis tools to examine the costs and benefits of their investments. Power quality improvement projects should not be an exception; however, energy problems are often evaluated using only one method, the ‘Simple Payback’. The evaluation methods that can properly include the impact of tax and cost of money are not used, e.g., Life Cycle Costing.

Monetary savings resulting from decreased maintenance, increased reliability, improved efficiency, and lower repair bills reduce overall operating costs. A decrease in costs translates to an increase in profit, which increases the value of the organization.

Regrettably, the energy industry has adopted the Simple Payback as the most common financial method used. Simple Payback is admittedly the easiest, but does not consider important issues. To properly assess a capital improvement project, such as a solution to power quality, Life Cycle Costing can be used. Both methods are described below.

### 1.7.1 Simple Payback

Simple Payback is calculated by dividing the initial, upfront cost of the project (the ‘first cost’), by the annual savings realized. The result is the number of years it takes for the savings to payback the initial capital cost. For example, if the first cost of a power quality improvement project was \$100,000, and the improvements saved \$25,000 annually, the project would have a four year payback.

As the name implies, the advantage of the Simple Payback method is that it is simple to use. It is also used as an indicator of both liquidity and risk. The cash spent for a project reduces the amount of money available to the rest of the organization (a decrease in liquidity), but that cash is returned in the form of reduced costs and higher net profit (an increase in liquidity). Thus the speed at which the cash can be ‘replaced’ is important in evaluating the investment.

Short payback also implies a project of lesser risk. As a general rule, events in the short-term are more predictable than events in the distant future. When evaluating an investment, cash flow in the distant future carries a higher risk, so shorter payback periods are preferable and more attractive.

A very simple payback analysis may ignore important secondary benefits that result from the investment. Direct savings that may occur outside the immediate payback period,

25

such as utility incentive programs or tax relief, can often be overlooked.

### 1.7.2 Life Cycle Costing

Proper financial analysis of a project must address more than just 'first cost' issues. By taking a very short-term perspective, the Simple Payback method undervalues the total financial benefit to the organization. Cost savings are ongoing, and continue to positively impact the bottom line of the company long after the project has been 'repaid'.

A full Life Cycle Costing financial analysis is both more realistic, and more powerful. Life Cycle Costing looks at the financial benefits of a project over its entire lifetime.

Electrical equipment may not need replacing for 10 years or more, so Life Cycle Costing would consider such things as the longer life of the equipment, maintenance cost savings, and the potential increased cost of replacement parts. In these cases, the time value of money is an important part of the investment analysis. Simply stated, money received in the future is less 'valuable' than money received today. When evaluating long-term projects, cash gained in the future must therefore be discounted to reflect its lower value than cash that could be gained today.

### 1.7.3 The Cost of Power Quality Problem Prevention

The costs associated with power quality prevention need to be included with the acquisition cost of sensitive equipment so that the equipment can be protected from disturbances. Installation costs must also be factored into the purchase of a major electrical product. The design and commissioning of data centres is a specific example. The costs that should be

considered include:

- site preparation (space requirements, air conditioning, etc.)
- installation
- maintenance
- operating costs, considering efficiency for actual operating conditions
- parts replacement
- availability of service on equipment
- consulting advice (if applicable)
- mitigating equipment requirements

The cost of purchasing any mitigating equipment must be weighed with the degree of protection required. In a non-critical application, for instance, it would not be necessary to install a UPS system to protect against power interruptions.

Power supply agreements with customers specify the responsibilities of both the supplier and the customers with regard to costs.

*For very large electrical devices, even if no power quality problems are experienced within the facility, steps should be taken to minimize the propagation of disturbances which may originate and reflect back into the utility distribution system. Many jurisdictions regulate the compatibility of electrical loads in order to limit power quality interactions.*

*Section 4.0, "Solving and Mitigating Electrical Power Problems," provides suggestions.*

## 2.0 Understanding Power Quality Concepts

### 2.1 The Electrical Distribution System

One of the keys to understanding power quality is to understand how electrical power arrives at the socket, and why distribution is such a critical issue.

Electrical power is derived from generation stations that convert another form of energy (coal, nuclear, oil, gas, water motion, wind power, etc.) to electricity. From the generator, the electricity is transmitted over long distances at high voltage through the bulk *transmission system*.

Power is taken from the bulk transmission system and is transmitted regionally via the regional supply system. Power is distributed locally through the distribution system and local utilities. The voltage of the *distribution system* is reduced to the appropriate level and supplied to the customer's service entrance.

**Figure 3: Electrical Transmission and Distribution**

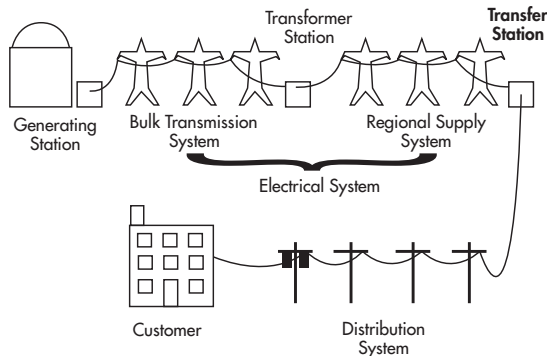

#### 2.1.1 Voltage Levels and Configurations

The power supplied to the customer by the utility will be either single-phase or three-phase power. Single-phase power is usually supplied to residences, farms, small office and small commercial buildings. The typical voltage level for single-phase power is 120/240 V (volts).

**Figure 4: 120/240 V Single-phase Service**

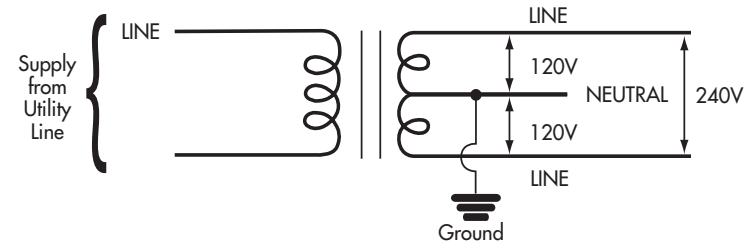

Three-phase power is usually supplied to large farms, as well as commercial and industrial customers.

**Figure 5: Typical 208 V Three-phase Wye Connected Service**

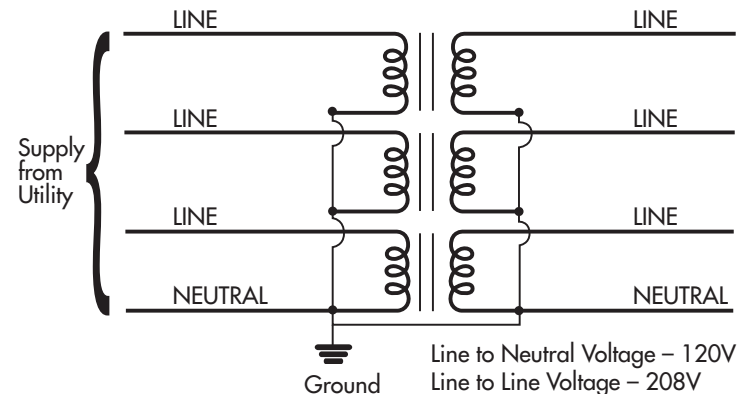

Typical voltage levels for three phase power supply are 120 V/208 V, 277 V/480 V (in the United States and Canada) or 347 V/600 V (in Canada).

Rotating equipment such as large motors and other large equipment require three-phase power to operate, but many loads require only single-phase power. Single-phase power is obtained from a three-phase system by connecting the load between two phases or from one phase to a neutral conductor.

Different connection schemes result in different voltage levels being obtained.

**Figure 6: Grounded Wye Connection**

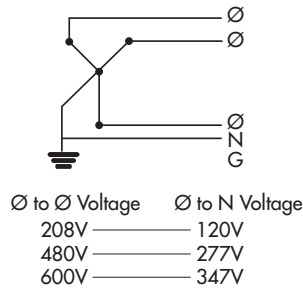

### 2.1.2 Site Distribution

Electrical power enters the customer's premises via the service entrance and then passes through the billing meter to the panel board (also referred to as the "fuse box", "breaker panel", etc.). In most residential or commercial installations electrical circuits will be run from this panel board.

**Figure 7: Typical Residential Service**

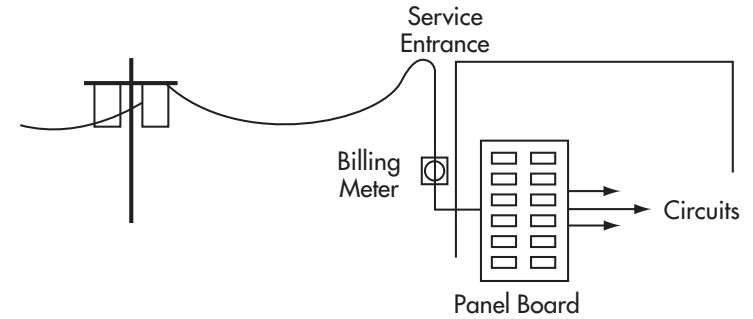

In larger distribution systems this power panel board will supply other panel boards which, in turn, supply circuits.

**Figure 8: Service with Branch Panel Boards**

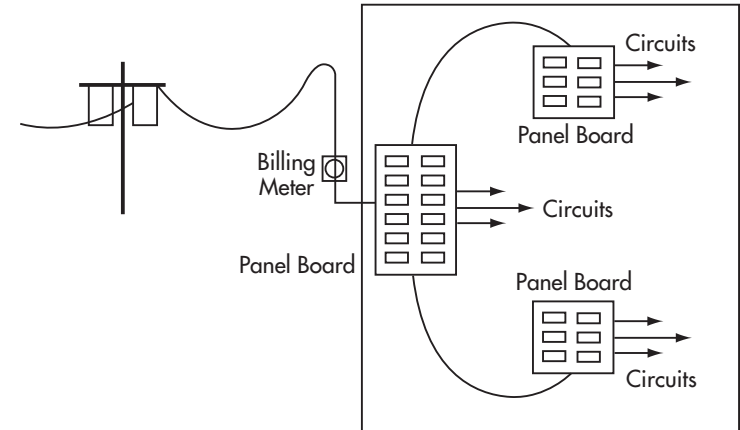

A transformer is used if a different voltage or isolation from the rest of the distribution system is required. The transformer effectively creates a new power supply system (called a separately derived power source) and a new grounding point on the neutral.

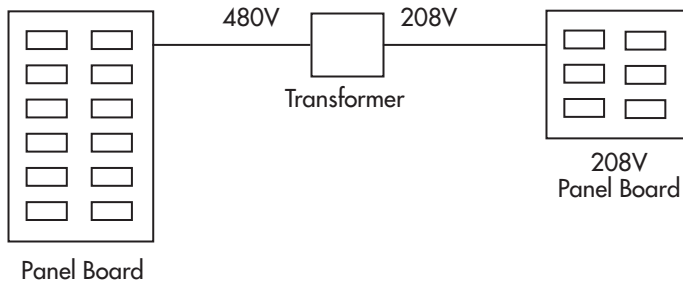
**Figure 9: Typical Transformer Installation**

## 2.2 Basic Power Quality Concepts

### 2.2.1 Grounding and Bonding

#### Grounding

Grounding is one of the most important aspects of an electrical distribution system but often the least understood. Your Electrical Code sets out the legal requirements in your jurisdiction for safety standards in electrical installations.

For instance, the Code may specify requirements in the following areas:

- (a) *The protection of life from the danger of electric shock, and property from damage by bonding to ground non-current-carrying metal systems;*
- (b) *The limiting of voltage on a circuit when exposed to higher voltages than that for which it is designed;*
- (c) *The limiting of ac circuit voltage-to-ground to a fixed level on interior wiring systems;*
- (d) *Instructions for facilitating the operation of electrical apparatus*
- (e) *Limits to the voltage on a circuit that is exposed to lightning.*

In order to serve Code requirements, effective grounding that systematically connects the electrical system and its loads to earth is required.

Connecting to earth provides protection to the electrical system and equipment from superimposed voltages from lightning and contact with higher voltage systems. Limiting over voltage with respect to the earth during system faults and upsets provides for a more predictable and safer electrical system. The earth ground also helps prevent the build-up of potentially dangerous static charge in a facility.

The grounding electrode is most commonly a continuous electrically conductive underground water pipe running from the premises. Where this is not available the Electrical Codes describe other acceptable grounding electrodes.

Grounding resistances as low as reasonably achievable will reduce voltage rise during system upsets and therefore provide improved protection to personnel that may be in the vicinity.

Connection of the electrical distribution system to the grounding electrode occurs at the service entrance. The neutral of the distribution system is connected to ground at the service entrance. The neutral and ground are also connected together at the secondary of transformers in the distribution system. Connection of the neutral and ground wires at any other points in the system, either intentionally or unintentionally, is both unsafe (i.e., it is an Electrical Code violation) and a power quality problem.

## Equipment Bonding

Equipment bonding effectively interconnects all non-current carrying conductive surfaces such as equipment enclosures, raceways and conduits to the system ground.

The purpose of equipment bonding is:

- 1) To minimize voltages on electrical equipment, thus providing protection from shock and electrocution to personnel that may contact the equipment.
- 2) To provide a low impedance path of ample current-carrying capability to ensure the rapid operation of over-current devices under fault conditions.

**Figure 10: Equipment without Proper Equipment Bonding**

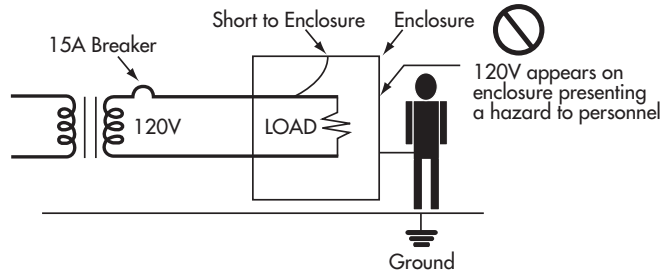

**Figure 11: Equipment with Proper Equipment Bonding**

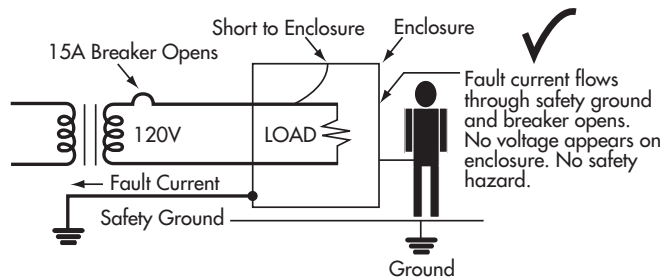

If the equipment were properly bonded and grounded the equipment enclosure would present no shock hazard and the ground fault current would effectively operate the over-current device.

## 3.0 Power Quality Problems

### 3.1 How Power Quality Problems Develop

Three elements are needed to produce a problematic power line disturbance:

- a source
- a coupling channel
- a receptor

If a receptor that is adversely affected by a power line deviation is not present, no power quality problem is experienced.

**Figure 12: Elements of a Power Quality Problem**

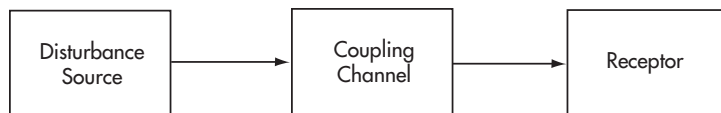

The primary coupling methods are:

#### 1. Conductive coupling

A disturbance is conducted through the power lines into the equipment.

#### 2. Coupling through common impedance

Occurs when currents from two different circuits flow through common impedance such as a common ground. The voltage drop across the impedance for each circuit is influenced by the other.

#### 3. Inductive and Capacitive Coupling

Radiated electromagnetic fields (EMF) occur during the operation of arc welders, intermittent switching of

contacts, lightning and/or by intentional radiation from broadcast antennas and radar transmitters. When the EMF couples through the air it does so either capacitively or inductively. If it leads to the improper operation of equipment it is known as Electromagnetic Interference (EMI) or Radio Frequency Interference (RFI). Unshielded power cables can act like receiving antennas.

Once a disturbance is coupled into a system as a voltage deviation it can be transported to a receptor in two basic ways:

- 1) A normal or transverse mode disturbance is an unwanted potential difference between two current-carrying circuit conductors. In a single-phase circuit it occurs between the phase or “hot” conductor and the neutral conductor.
- 2) A common mode disturbance is an unwanted potential difference between all of the current-carrying conductors and the grounding conductor. Common mode disturbances include impulses and EMI/RFI noise with respect to ground.

The switch mode power supplies in computers and ancillary equipment can also be a source of power quality problems.

The severity of any power line disturbance depends on the relative change in magnitude of the voltage, the duration and the repetition rate of the disturbance, as well as the nature of the electrical load it is impacting.

## 3.2 Power Quality Disturbances

Category	Typical Spectral Content	Typical Duration	Typical Voltage Magnitude
<b>1.0 Transients</b>			
<b>1.1 Impulsive Transient</b>			
1.1.1 Nanosecond	5 ns rise	<50 ns	
1.1.2 Microsecond	1 $\mu$ s rise	50 ns -1 ms	
1.1.3 Millisecond	0.1 ms rise	>1 ms	
<b>1.2 Oscillatory Transient</b>			
1.2.1 Low Frequency	<5 kHz	0.3-50 ms	0-4 per unit
1.2.2 Medium Frequency	5-5000 kHz	20 $\mu$ s	0-8 per unit
1.2.3 High Frequency	0.5-5 MHz	5 $\mu$ s	0-4 per unit
<b>2.0 Short Duration Variations</b>			
<b>2.1 Instantaneous</b>			
2.1.1 Sag		0.5-30 cycles	0.1-0.9 per unit
2.1.2 Swell		0.5-30 cycles	1.1-1.8 per unit
<b>2.2 Momentary</b>			
2.2.1 Interruption		0.5-30 cycles	<0.1 per unit
2.2.2 Sag		30 cycles-3 s	0.1-0.9 per unit
2.2.3 Swell		30 cycles-3 s	1.1-1.4 per unit
<b>2.3 Temporary</b>			
2.3.1 Interruption		3 s-1 min	<0.1 per unit
2.3.2 Sag		3 s-1 min	0.1-0.9 per unit
2.3.3 Swell		3 s-1 min	1.1-1.2 per unit
<b>3.0 Long Duration Variations</b>			
3.1 Sustained Interruption		>1 min	0.0 per unit
3.2 Under-voltages		>1 min	0.8-0.9 per unit
3.3 Over voltages		>1 min	1.1-1.2 per unit
<b>4.0 Voltage Imbalance</b>		Steady State	0.5-2%
<b>5.0 Waveform Distortion</b>			
5.1 DC Offset	0-100th Harmonic	Steady State	0-0.1%
5.2 Harmonics	0-6 KHz	Steady State	0-20%
5.3 Inter-harmonics		Steady State	0-2%
5.4 Notching		Steady State	
5.5 Noise	Broadband	Steady State	0-1%
<b>6.0 Voltage Fluctuations</b>	<25 Hz	Intermittent	0.1-7%
<b>7.0 Frequency Variations</b>		<10 s	

The IEEE has provided a comprehensive summary of the types and classes of disturbances that can affect electrical power. The classifications are based on length of time, magnitude of voltage disturbance and the frequency of occurrence. These classifications are shown in the previous table.

## 3.3 Load Sensitivity: Electrical Loads that are Affected by Poor Power Quality

### 3.3.1 Digital Electronics

Digital electronics, computers and other microprocessor based equipment may be more sensitive to power line disturbances than other electrical equipment depending on the quality of their power supply and how they are interconnected. The circuits in this equipment operate on direct current (DC) power. The source is an internal DC power supply which converts, or *rectifies*, the AC power supplied by the utility to the various DC voltage levels required. A computer power supply is a *static converter* of power. Variations in the AC power supply can therefore cause power quality anomalies in computers.

The Computer Business Equipment Manufacturers Association Curve (CBEMA, now called the ITIC Curve) published in the IEEE Orange Book is intended to illustrate a suggested computer susceptibility profile to line voltage variations. The ITIC curve is based on generalized assumptions, is not an industry standard and is not intended for system design purposes. No ITIC member company is known to have made any claim for product performance or disclaimer for non-performance for their products when operated within or outside the curve. The ITIC curve should not be mistakenly used as a utility power supply performance curve.

**Figure 13: Computer Susceptibility Profile to Line Voltage Variations and Disturbances – The ITIC Curve**

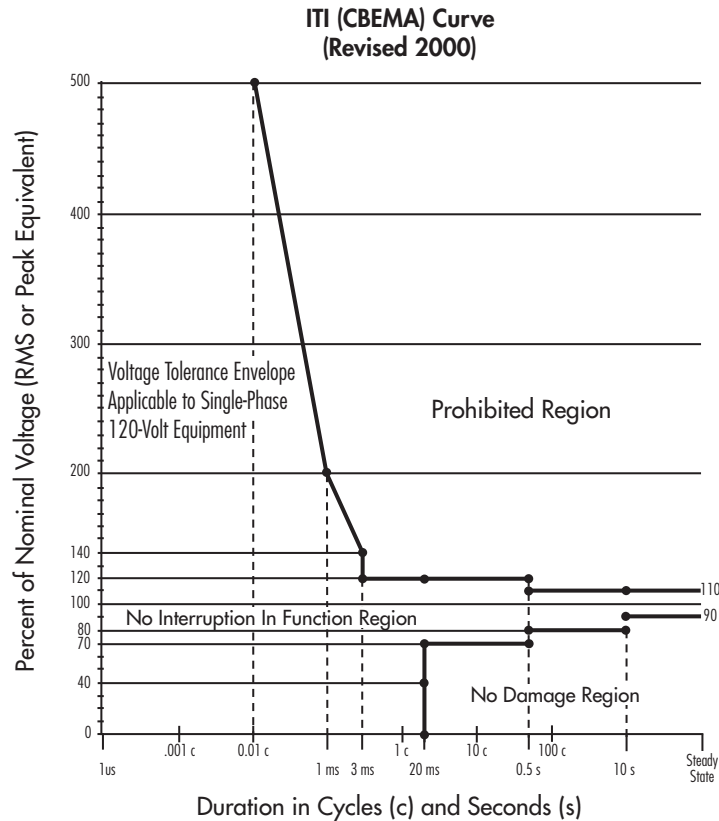

The susceptibility profile implies that computers can tolerate slow variations from -13% to + 5.8%, and greater amplitude disturbances can be tolerated as their durations become shorter. In fact, many computers can run indefinitely at 80% of their nominal supply voltage; however, such operation does lead to premature wear of the power supply.

While the operating characteristics of computer peripherals may at one time have been more dependent on the types of power supply designs and components used, generalizations that infer that computers are highly sensitive to small deviations in power quality are no longer true.

There is also no validity in the contention that, as the operating speed of a computer increases, so does its sensitivity to voltage variations. IT equipment sensitivity is due to the manner in which its power supply components interact with the supplied AC power.

### 3.3.2 Lighting

There are three major effects of voltage deviations on lighting:

1. reduced lifespan
2. change of intensity or output (voltage flicker)
3. short deviations leading to lighting shutdown and long turn-on times

For incandescent lights the product life varies inversely with applied voltage, and light output increases with applied voltage. In High Intensity Discharge (HID) lighting systems, product life varies inversely with number of starts, light output increases with applied voltage and restart may take considerable time. Fluorescent lighting systems are more forgiving of voltage deviations due to the nature of electronic

ballasts. Ballasts may overheat with high applied voltage and these lights are usually less susceptible to flicker.

Information on lighting is available from the companion “lighting reference guide” that can be easily found through the various internet web search engines.

### 3.3.3 Motors

Voltages above the motor’s rated value, as well as voltage phase imbalance, can cause increased starting current and motor heating. Reduced voltages cause increased full-load temperatures and reduced starting torques.

## 3.4 Types and Sources of Power Quality Problems

### 3.4.1 Transients, Short Duration and Long Duration Variations

A general class of power quality variations (summarized in the following charts) are instantaneous variations. These are subdivided as:

- Transients (Impulsive and Oscillatory; up to 50 ms)
- Short-Duration (0.5 cycles to 1 minute)
- Long-Duration (>1 minute but not a steady state phenomenon)

Generally, instantaneous variations are unplanned, short-term effects that may originate on the utility line or from within a facility. Due to the nature and number of events that are covered by this class of power quality problem, a summary chart has been provided to highlight the key types of variation.

## Power Line Disturbances Summary

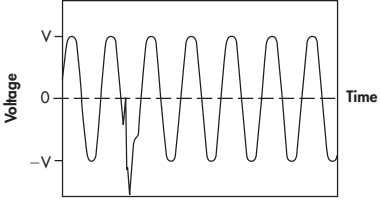
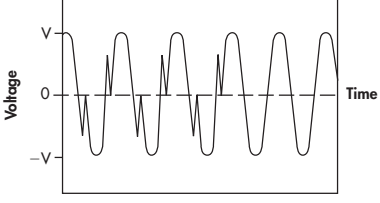
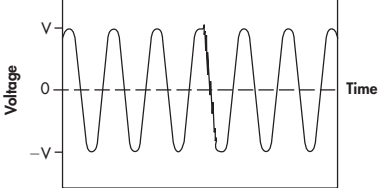

## Power Line Disturbances Summary (1 of 4)

DISTURBANCES	SYMPTOMS	POSSIBLE CAUSES	POSSIBLE RESULTS	COMMENTS AND SOLUTIONS
<p><b>Duration</b></p> <ul style="list-style-type: none"> <li>typically &lt; 0.5 cycles</li> </ul> <p><b>Coupling Mechanism</b></p> <ul style="list-style-type: none"> <li>conductive, electromagnetic</li> </ul> <p><b>Duration</b></p> <ul style="list-style-type: none"> <li>impulsive</li> <li>oscillatory</li> </ul>	<ul style="list-style-type: none"> <li>high amplitude, short duration voltage disturbances</li> <li>can occur in common and normal mode</li> </ul>	<ul style="list-style-type: none"> <li>switching inductive loads on or off (motors, relays, transformers, x-ray equipment, lighting ballasts)</li> <li>operation of older UPS/SPS systems may cause notching</li> <li>arcing grounds</li> <li>lighting</li> <li>capacitor switching</li> <li>fault clearing</li> </ul>	<ul style="list-style-type: none"> <li>electronic interference</li> <li>microprocessor based equipment errors</li> <li>hardware damage of electronic equipment</li> <li>current limiting fuse operation</li> </ul>	<ul style="list-style-type: none"> <li>Transient problems are mainly due to the increased use of electronic equipment without regard for the realities of normal power system operation and the operation of the customers' facility</li> <li>It is sometimes very difficult to trace the source of a transient.</li> <li>Transients usually have less energy than momentary disturbances.</li> <li>Transient suppressors rarely protect against equipment generated transients.</li> <li>There is a general consensus that most transients get into computer logic and memory circuits through poor wiring or EMI, not by conduction.</li> <li>Normal mode impulses are typically the result of the switching of heavy loads, or of power factor connection capacitors.</li> <li>Common mode impulses are often caused by lightning.</li> </ul>
<p><b>Impulsive Non-Periodic</b></p>  <p>Voltage vs. Time</p>	<p>Non-periodic impulses which increase instantaneous voltage</p>			
<p><b>Impulsive Periodic</b></p>  <p>Voltage vs. Time</p>	<p>Periodic impulses which increase or decrease the instantaneous voltage</p>			
<p><b>Oscillatory</b></p>  <p>Voltage vs. Time</p>	<p>High frequency oscillations (from a few hundred Hz to 500 kHz) that decay to zero within a few milliseconds</p>			

**Power Line Disturbances Summary (2 of 4)**

**Power Line Disturbances Summary (3 of 4)**

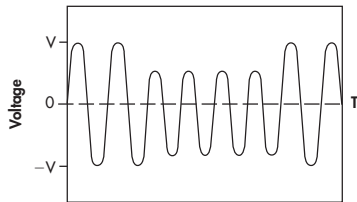
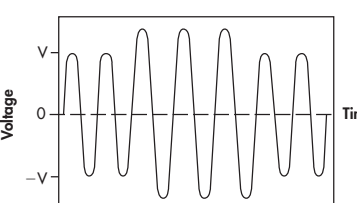
SHORT DURATION DISTURBANCES	DISTURBANCES	SYMPTOMS	POSSIBLE CAUSES	POSSIBLE RESULTS	COMMENTS AND SOLUTIONS	
	<p><b>Duration</b></p> <ul style="list-style-type: none"> <li>• 0.5s - 1 min.</li> </ul> <p><b>Coupling Mechanism</b></p> <ul style="list-style-type: none"> <li>• conductive</li> <li>• sags</li> <li>• swells</li> <li>• interruptions</li> </ul>					
	<p><b>Sag</b></p> 	Low voltage in one or more phases	<ul style="list-style-type: none"> <li>• starting large loads (motors, air conditioners, electric furnaces, etc)</li> <li>• overloaded wiring and incorrect fuse rating</li> <li>• fuse and breaker clearing</li> <li>• lightning (indirect cause due to effects of lightning arresters)</li> <li>• ground faults</li> <li>• utility switching/equipment failure</li> <li>• utility reclosing activity</li> </ul>	<ul style="list-style-type: none"> <li>• related computer systems failures</li> <li>• hardware damage unlikely</li> <li>• flickering of lights</li> <li>• motor stalling</li> <li>• reduced life of motors and driven equipment</li> <li>• digital clock flashing</li> </ul>	<ul style="list-style-type: none"> <li>• When starting large loads, such as motors, high inrush currents are produced which drop the voltage for short periods. This is a relatively common problem and can be prevented by using reduced voltage motor starters, by reducing the number of large loads operating simultaneously, by restricting the number of motor starts at any given time, by transferring the large load to its own circuit, by upgrading feeder voltage, and by using cable of proper rating.</li> <li>• Although lightning may initially cause voltage spikes or surges near its point of impact, surge arrestors momentarily shorten the power line, producing sags that may be conducted for a considerable distance through the system.</li> <li>• Electrical equipment may respond to a sag as it would to a power interruption.</li> </ul>	
	<p><b>Swell</b></p> 	High RMS voltage disturbance on one or more phases	<ul style="list-style-type: none"> <li>• open neutral connection</li> <li>• insulation breakdown</li> <li>• sudden load reduction</li> <li>• improper wiring, which restricts the amount of current available for loads</li> <li>• fault on one line causing voltage rise on other phases</li> <li>• open conductor fault</li> </ul>	<ul style="list-style-type: none"> <li>• light flicker</li> <li>• degradation of electrical contacts</li> </ul>		
	<p><b>Voltage Flicker Repetitive</b></p>	Repetitive sags or swells in the voltage	<ul style="list-style-type: none"> <li>• large cyclic loads such as spot welders, induction arc furnaces, and motors when cycled</li> </ul>	<ul style="list-style-type: none"> <li>• light flicker</li> </ul>		

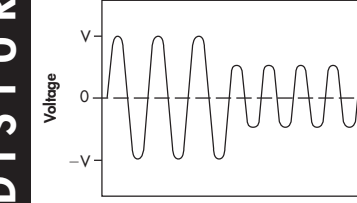
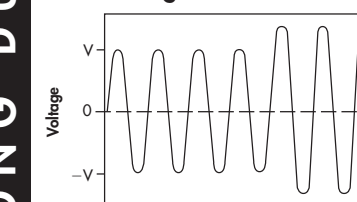
LONG DURATION DISTURBANCES	DISTURBANCES	SYMPTOMS	POSSIBLE CAUSES	POSSIBLE RESULTS	COMMENTS AND SOLUTIONS	
	<p><b>Voltage Deviations</b></p> <p>Duration:</p> <ul style="list-style-type: none"> <li>• &gt;120 cycles (2 sec)</li> </ul> <p>Coupling Mechanism:</p> <ul style="list-style-type: none"> <li>• conductive</li> </ul>					
	<p><b>Undervoltage</b></p> 	Any long-term change above (overvoltages) or below (undervoltages) the prescribed input voltage range for a given piece of equipment. (undervoltages) the prescribed input voltage range for a given piece of equipment.	<ul style="list-style-type: none"> <li>• overloaded customer wiring loose or corroded connections</li> <li>• unbalanced phase loading conditions</li> <li>• faulty connections or wiring overloaded distribution system</li> <li>• incorrect tap setting</li> <li>• reclosing activity</li> </ul>	<ul style="list-style-type: none"> <li>• errors of sensitive equipment</li> <li>• low efficiency and reduced life of electrical equipment, such as some motors, heaters</li> <li>• lengthens process time of infrared and resistance heating processes</li> <li>• hardware damage</li> <li>• dimming of incandescent lights, and problems in turning on fluorescent lights</li> </ul>	<ul style="list-style-type: none"> <li>• Some municipal utilities have a list of overloaded distribution transformers, which can indicate areas prone to undervoltage conditions.</li> <li>• Undervoltages can be reduced by practicing regular maintenance of appliance cable and connections, checking for proper fuse ratings, transferring loads to separate circuits, selecting a higher transformer tap setting, replacing an overloaded transformer or providing an additional feeder.</li> </ul>	
	<p><b>Brownouts</b></p>	A type of voltage fluctuation. Usually a 3-5% voltage reduction.	<ul style="list-style-type: none"> <li>• poor wiring or connections</li> <li>• high power demand within building or local area</li> <li>• intentional utility voltage reduction to reduce load under emergency system conditions</li> <li>• planned utility testing</li> </ul>			
	<p><b>Overvoltage</b></p> 		<ul style="list-style-type: none"> <li>• improper application of power factor correction capacitors</li> <li>• incorrect tap setting</li> </ul>	<ul style="list-style-type: none"> <li>• overheating and reduced life of electrical equipment and lighting</li> <li>• blistering of infrared processes</li> </ul>		
			<ul style="list-style-type: none"> <li>• Ensuring that any power factor correction capacitors are properly applied</li> <li>• Changing the transformers tap setting</li> </ul>			

**Power Line Disturbances Summary (4 of 4)**

**LONG DURATION DISTURBANCES**

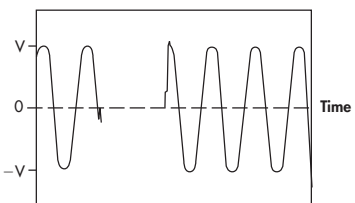
DISTURBANCES	SYMPTOMS	POSSIBLE CAUSES	POSSIBLE RESULTS	COMMENTS AND SOLUTIONS
<p><b>Power Interruptions</b>                      Duration:                      • momentary interruptions; <math>\leq 2</math> mins                      • sustained interruptions: <math>&gt; 2</math> mins                      Coupling Mechanism:                      • conductive</p>				
<p><b>Power Interruptions</b></p> 	<p>Total loss of input voltage. Often referred to as a "blackout" or "failure" for events of a few cycles or more, or "dropout" or "glitch" for failures of shorter duration.</p>	<ul style="list-style-type: none"> <li>• operation of protective devices in response to faults that occur due to acts of nature or accidents</li> <li>• malfunction of customer equipment</li> <li>• fault at main fuse box tripping supply</li> </ul>	<ul style="list-style-type: none"> <li>• loss of computer/controller memory</li> <li>• equipment shutdown/failure</li> <li>• hardware damage</li> <li>• product loss</li> </ul>	<ul style="list-style-type: none"> <li>• employing UPS systems,</li> <li>• allowing for redundancy,</li> <li>• installing generation facilities in the customer's facility</li> </ul>

### 3.4.2 Steady State Disturbances

#### 3.4.2.1 Waveform Distortion and Harmonics

Harmonics are currents and voltages with frequencies that are whole-number multiples of the fundamental power line frequency (which is 60 Hz in North America). Harmonics distort the supplied 60 Hz voltage and current waveforms from their normal sinusoidal shapes.

Each harmonic is expressed in terms of its order. For example, the second, third, and fourth order harmonics have frequencies of 120 Hz, 180 Hz, and 240 Hz, respectively. As order, and therefore frequency, of the harmonics increases, the magnitude normally decreases. Therefore, lower order harmonics, usually the fifth and seventh, have the most effect on the power system. Due to the nature of power conversion techniques, odd numbered harmonics are usually the only frequencies of concern when dealing with harmonic problems. The presence of low levels of even harmonics in a system requires expert mitigation advice from a power quality professional.

The effect of a given harmonic on the power system can be seen by superimposing the harmonic on the fundamental waveform, to obtain a composite:

**Figure 14: Superposition of Harmonic on Fundamental: Initially In-Phase**

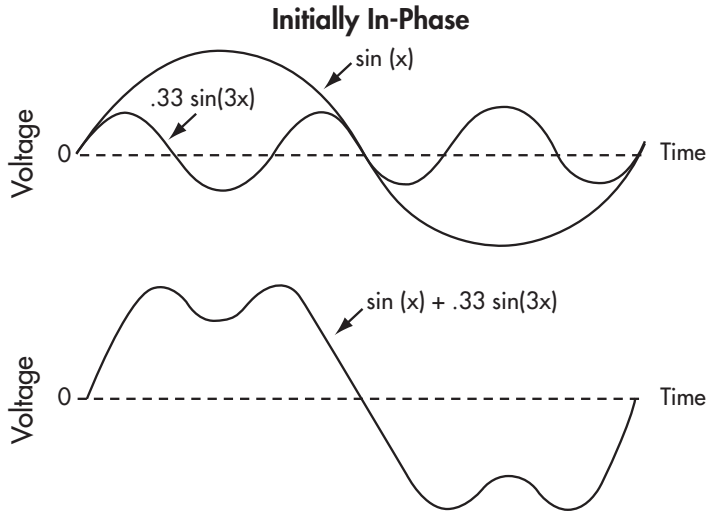

50

In this example, the two waveforms begin in-phase with each other, and produce a distorted waveform with a flattened top. The composite waveform can be changed by adding the same harmonic, initially out-of-phase with the fundamental, to obtain a peaked effect:

**Figure 15: Superposition of Harmonic on Fundamental: Initially Out-of-Phase**

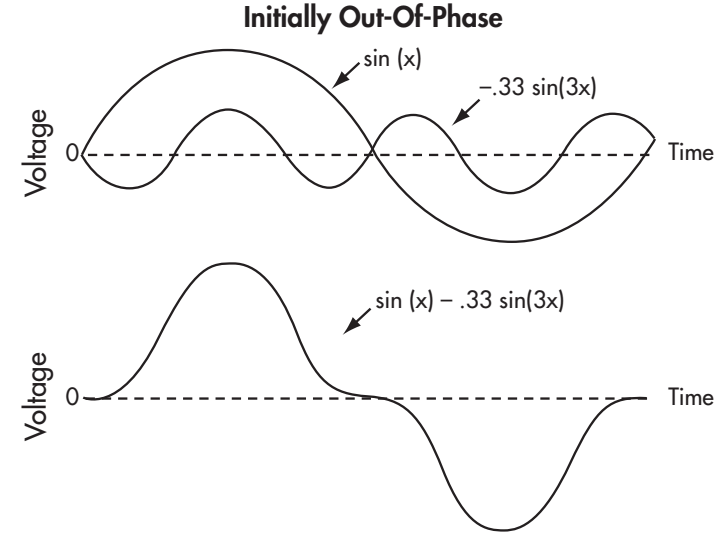

51

Harmonics can be differentiated from transients on the basis that transients are not periodic and are not steady state phenomena.

## Production and Transmission

Most harmonics result from the operation of customer loads, at residential, commercial and industrial facilities.

**Figure 16: Main Sources of Harmonics**

Common Sources of Harmonics		
Sector	Sources	Common Problems
Industrial	Variable speed drives welders, large UPS systems, lighting system	<ul style="list-style-type: none"> <li>• Overheating and fuse blowing of power factor correction capacitors</li> <li>• Overheating of supply transformers</li> <li>• Tripping of overcurrent protection</li> </ul>
Commercial	Computers, electronic office equipment, lighting	<ul style="list-style-type: none"> <li>• Overheating of neutral conductors and transformers</li> <li>• Interference</li> </ul>
Residential	Personal computers, lighting, electronic devices	<ul style="list-style-type: none"> <li>• Generally not a problem</li> <li>• However, high density of electronic loads could cause overheating of utility transformers</li> </ul>

Harmonics are caused by any device or equipment which has nonlinear voltage-current characteristics. For example, they are produced in electrical systems by solid state power converters such as rectifiers that conduct the current in only a portion of each cycle. Silicon Controlled Rectifiers (SCRs) or thyristors are examples of this type of power conversion device.

The levels of harmonic current flowing across the system impedance (which varies with frequency) determine the harmonic voltage distortion levels.

**Figure 17: Harmonics Produced by Three-Phase Controlled Loads**

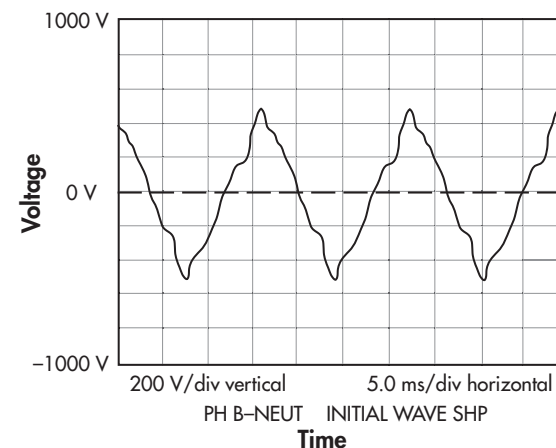

(Reproduced with Permission of Basic Measuring Instruments, from "Handbook of Power Signatures", A. McEachern, 1988)

Aside from solid state power converters, loads may also produce harmonics if they have nonlinear characteristics, meaning that the impedance of the device changes with the applied voltage. Examples include saturated transformers and gaseous discharge lighting, such as fluorescent, mercury arc and high pressure sodium lights.

As harmonic currents flow through the electrical system, they may distort the voltage seen by other electrical equipment. Since the system impedances are usually low (except during resonance), the magnitudes of the voltage harmonics, and the extent of voltage distortion are usually lower than that for the corresponding current distortion. Harmonics represent a steady state problem, since they are present as long as the harmonic generating equipment is in operation.

Third harmonic currents are usually most apparent in the neutral line. These occur due to the operation of single-phase nonlinear loads, such as power supplies for electronic equipment, computers and lighting equipment.

As lighting equipment has been a cause of many neutral problems adequate precaution must be taken to mitigate the harmonic emission of lighting equipment, in particular in case of re-lamping. These harmonic currents occur due to the operation of single-phase nonlinear loads, such as power supplies for electronic equipment and computers. The third harmonic produced on each phase by these loads adds in the neutral. In some cases, the neutral current can be larger than the phase currents due to these third harmonics.

### Effects of Harmonics

In many cases, harmonics will not have detrimental effects on equipment operation. If the harmonics are very severe, however, or if loads are highly sensitive, a number of problems may arise. The addition of power factor correction capacitors to harmonic producing loads can worsen the situation, if they have parallel resonance with the inductance of the power system. This results in amplifying the harmonic currents producing high harmonic voltages.

Harmonics may show up at distant points from their source, thus causing problems for neighbouring electrical end-users, as well as for the utility. In flowing through the utility supply source impedance, harmonic currents produce distortion in the utility feeder voltage.

**Figure 18: Harmonic Effects on Equipment**

EQUIPMENT	HARMONIC EFFECTS	RESULTS
Capacitors (all; not just those for power factor correction)	<ul style="list-style-type: none"> <li>– capacitor impedance decreases with increasing frequency, so capacitors act as sinks where harmonics converge; capacitors do not, however, generate harmonics</li> <li>– supply system inductance can resonate with capacitors at some harmonic frequency causing large currents and voltages to develop</li> <li>– dry capacitors cannot dissipate heat very well, and are therefore more susceptible to damage from harmonics</li> <li>– breakdown of dielectric material</li> <li>– capacitors used in computers are particularly susceptible, since they are often unprotected by fuses or relays</li> </ul>	<ul style="list-style-type: none"> <li>– heating of capacitors due to increased dielectric losses</li> <li>– short circuits</li> <li>– fuse failure</li> <li>– capacitor failure</li> </ul>
Transformers	<ul style="list-style-type: none"> <li>– current harmonics cause higher transformer losses</li> </ul>	<ul style="list-style-type: none"> <li>– transformer heating</li> <li>– reduced life</li> <li>– increased copper and iron losses</li> <li>– insulation stress</li> <li>– noise</li> </ul>

In addition to electrical conduction, harmonics can be coupled inductively or capacitively, thus causing interference on analog telecommunication systems. For example, humming on telephones can be caused by induced harmonic distortion.

A power harmonic analysis can be used to compare distortion levels against limits of acceptable distortion. In addition, the operation of some solid state devices will produce a notched effect on the voltage waveform.

### Harmonic Prevention and Reduction

It is very important when designing an electrical system, or retrofitting an existing one, to take as many precautions as necessary to minimize possible harmonic problems. This requires advanced planning and, potentially, additional capital. The complete electrical environment must be considered.

56

#### Filters

Harmonic filters can be used to reduce the amplitude of one or more harmonic currents or voltages. Filters may either be used to protect specific pieces of equipment, or to eliminate harmonics at the source. Since harmonic filters are relatively large, space requirements may have to be budgeted for.

In some situations, improperly tuned filters may shift the resonant frequencies close to the characteristic harmonics of the source. The current of the high harmonics could excite the resonant circuit and produce excessive voltages and attract high oscillating harmonic currents from elsewhere in the system.

### Capacitors

Harmonic amplification due to resonance associated with capacitor banks can be prevented by using converters with high pulse numbers, such as twelve pulse units, thereby reducing high-amplitude low order harmonics. A similar effect occurs with pulse width modulated converters.

Method	Advantages	Disadvantages
Change the size of the capacitor bank to shift the resonant point away from the major harmonic	<ul style="list-style-type: none"> <li>• relatively low incremental cost</li> <li>• ease of tuning</li> </ul>	<ul style="list-style-type: none"> <li>• vulnerable to power system changes</li> </ul>
Place an inductor in series with the capacitor bank, and tune their series resonance below the major harmonics	<ul style="list-style-type: none"> <li>• better ability to minimize harmonics</li> <li>• flexibility for changing load conditions</li> </ul>	<ul style="list-style-type: none"> <li>• series inductor increases the fundamental frequency voltage of the capacitor; therefore, a higher rated capacitor may be required</li> </ul>

57

### Telephone Line Interference

Telephone interference can be reduced by the aforementioned prevention and reduction methods, by rerouting the telephone lines, improved shielding and balance of telephone cables, compatible grounding of telephone cables, or by reducing the harmonic levels on the power line. The degree of telephone interference can be expressed in terms of the Telephone Interference Factor (TIF).

### Harmonic Study

Single calculation of resonant frequencies, transient network analysis, and digital simulation are among the techniques available today to perform harmonic studies. These tools could be used to accurately model the power network, the

harmonic sources, and perform the harmonic analysis in the same manner as traditional load flow, short circuit and transient stability studies are conducted. Experienced consultants may be approached to conduct or assist in a harmonic study.

### Equipment Specifications

Consider the effect on your power system when ordering harmonic producing equipment. Large projects may require a pre-installation harmonic study. Be prepared for filtering requirements if necessary to ensure compatibility with the power system. If a harmonic filter is required, a description of the power system should be considered in its design, including:

- fault level at the service entrance
- rating and impedance of transformers between the service entrance and the input to the power conditioning equipment
- details of all capacitor banks in the facility.

Where a choice is available, consider using equipment with low harmonic emission characteristics. This should be explicitly stated in the manufacturer's literature. Where Variable Speed Drives (VSDs) will be deployed, active front end designs generate lower harmonic levels and have a power factor close to unity. Variable Speed Drives are also the same equipment as Adjustable Speed Drives (ASDs); Variable Frequency Drives (VFDs); Adjustable Frequency Drives (AFDs), etc.

#### 3.4.2.2 Flicker

Flicker is the impact a voltage fluctuation has on the luminous intensity of lamps and fluorescent tubes such that they are

perceived to 'flicker' when viewed by the human eye. The level at which it becomes irritating is a function of both the magnitude of the voltage change and how often it occurs. A voltage flicker curve indicates the acceptable magnitude and frequency of voltage fluctuations on a distribution system. Flicker is caused by rapidly changing loads such as arc furnaces, electrical welders, and the starting and stopping of motors.

Figure 19: Flicker Curve IEEE 519-1992

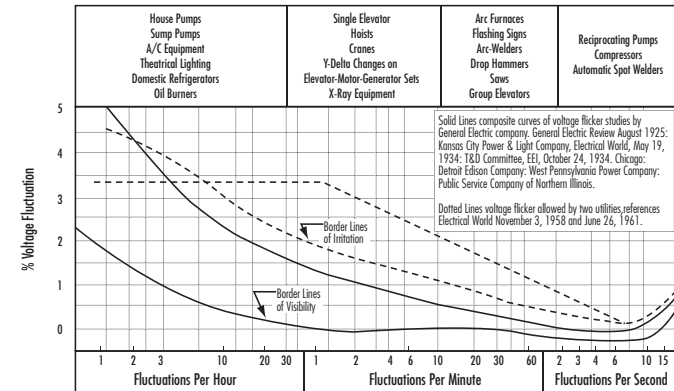

### 3.4.3 Distribution and Wiring Problems

Many power quality problems are due to improper or ineffective electrical distribution wiring and/or grounding within the customer's site.

Grounding and distribution problems can result from the following:

- improper application of grounding electrodes or mistakenly devising alternate "grounds" or grounding systems

- high impedances in the neutral current return path or fault current return path
- excessive levels of current in the grounding system, due to wiring errors or equipment malfunction

It must be realized that although mitigating equipment when properly applied will resolve voltage quality problems, it will do nothing to resolve wiring or grounding problems. It is essential that the site distribution and grounding system be designed and installed properly and in accordance with the applicable Electrical Safety Code to ensure the safety of personnel and proper equipment operation. All electrical equipment used must be approved by the applicable authority, such as the CSA or UL, or inspected by the local authority in order to ensure that regulatory minimum safety standards have been achieved.

#### 3.4.3.1 Fault Protection in Utility Distribution Systems

Faults resulting in **overvoltages** and over-currents may occur in the utility system, typically due to lightning, construction, accidents, high winds, icing, tree contact or animal intervention with wires.<sup>4</sup> These faults are normally detected by over-current relays which initiate the operation of fault clearing by equipment.

Faults may be classified as temporary or permanent. Temporary faults may be caused by momentary contact with tree limbs, lightning flashover, and animal contact. Permanent faults are those which result in repairs, maintenance or equipment replacement before voltage can be restored. Protection and control equipment automatically

<sup>4</sup> A worst case event of tree contact with utility lines contributing to power problems took place on August 15, 2003. See "U.S.- Canada Power System Outage Task Force Final Report on the August 14, 2003 Blackout in the United States and Canada: Causes and Recommendations," April 2004

disconnects the faulted portion of a system to minimize the number of customers affected.

The utility distribution system includes a number of devices such as circuit breakers, automatic circuit re-closers and fused cutouts which clear faults. Automatic re-closers and re-closing breakers restore power immediately after temporary faults. Fused cutouts that have operated must have their fuse replaced before power can be restored. These protective devices can reduce the number of customers affected by a fault, reduce the duration of power interruptions resulting from temporary faults and assist in locating a fault, thereby decreasing the length of interruptions.

Automatic reclosers and reclosing breakers open a circuit on over-current to prevent any further current flow, and reclose it after a short period of time. If a fault does not disappear after one reclosure operation, additional opening/reclosing cycles can occur.

**Figure 20: Example of a Repetitive Reclosure Operation**

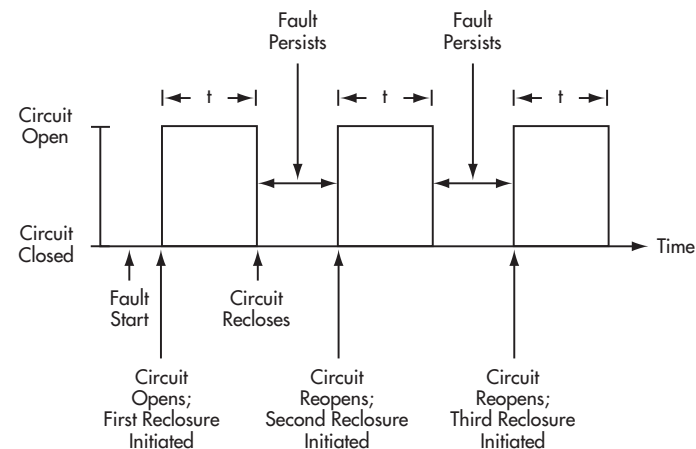

Normally a few seconds are required to clear a fault and energize the appropriate circuitry for a reclosure. The reclosing interval for a recloser is the open circuit time between an automatic opening and the succeeding automatic reclosure. In the above diagram, three intervals of duration 't' are indicated.

Some hydraulic reclosers may be able to provide instantaneous (0.5 seconds) or four second reclosing intervals. In addition to these reclosers, circuit breakers at substations, on the secondary or distribution side, are equipped with timers which allow a range of reclosing times to be selected. A commonly available range is 0.2 to 2 seconds.

**Figure 21: Effect of Multiple Reclosure Operation on Voltage**

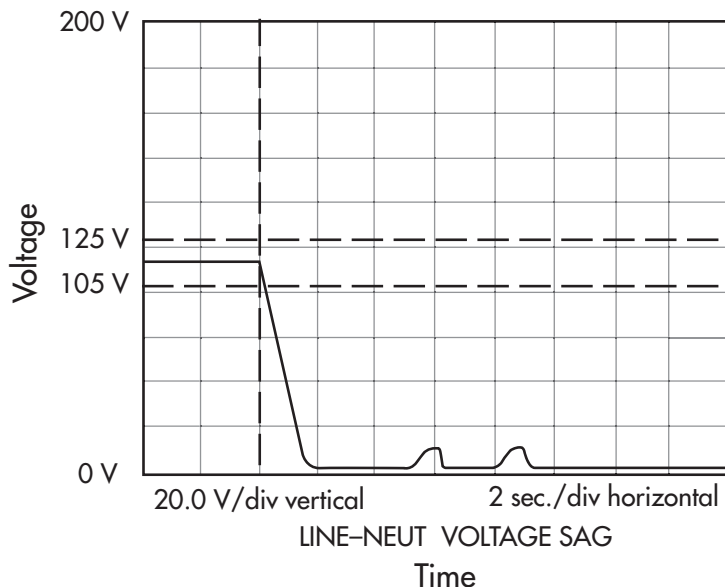

(Reproduced with Permission of Basic Measuring Instruments, from "Handbook of Power Signatures", A. McEachern, 1988)

**Figure 22: Reclosing Interval for Hydraulic and Electrical Control Types ("t<sub>1</sub>" 1st reclosing operation etc.)**

Type of Control	Reclosing Interval (Seconds)		
	t <sub>1</sub>	t <sub>2</sub>	t <sub>3</sub>
Hydraulic	2	2	2
Electronic	<0.5	2	5-10

When a solid fault on a feeder is cleared, the voltage at the fault point declines to near zero instantaneously. However, the time constant in the detection circuitry results in the graph above. In this figure, small voltage rises indicate when reclosure was attempted unsuccessfully due to the persistence of the fault.

If a fault persists, the recloser or breaker may lock open, or a fuse or sectionalizer will operate. An autoreclosure on one feeder that is faulted can produce a disturbance that travels on neighbouring feeders.

Customers frequently mistake the effects of a temporary (0.5s - 2s) interruption, such as the loss of time-keeping abilities of digital clocks, as evidence of a sustained power interruption. The fact that most High Intensity Discharge (HID) lighting, which is frequently used in industrial settings, can take 10-20 minutes to come back on after a fault has cleared is a further example of an apparent power supply problem that actually represents normal operation of the utility distribution network. The lengthy period of time before light is restored results from the characteristics of the lighting system. Although special HID systems are available that eliminate this problem, they do not represent the majority that are currently used.

### 3.4.4 Voltage Unbalance

A voltage unbalance is a condition in a three-phase system in which the measured r.m.s. values of the phase voltages or the phase angles between consecutive phases are not all equal. Voltage unbalance is a significant concern for users that have poorly distributed loads and impedance mismatches. An excessive level of voltage unbalance can have serious impacts on induction motors, leading to large inefficiencies causing over-heating and winding failure. Excessive losses in the motor may cause over-current protection systems to operate. Although induction motors are designed to accept a small level of unbalance they have to be derated if the voltage unbalance is 2% or higher. If an induction motor is oversized, then some protection is built into its operation although the motor does not operate at the best efficiency and power factor. Voltage unbalance may also have an impact on AC variable speed drive systems unless the DC output of the drive rectifier is well filtered.

64

There are two major sources of voltage unbalance:

- 1) the unbalance of load currents, which can be controlled by making sure load currents are balanced to within 10%
- 2) high impedance or open neutrals, which represent a major wiring fault that needs to be corrected by your electrician.

## 3.5 Relative Frequency of Occurrence

Frequently, the source of a disturbance originates within a customer's plant or building. Some pre-existing data studies conducted in the United States indicate that as many as 90% of the origins of power quality problems originate within a

customer's or a neighbour's facility. Many of these disturbances are due to the use of disturbance producing equipment, improper wiring and grounding, or the misapplication of mitigating equipment.

Some disturbances are caused by normal utility operations such as fault clearing, capacitor switching, and line switching. Although fewer in number than those generated within a facility, these events can cause great difficulty for customers that have equipment incompatible with these normal operations.

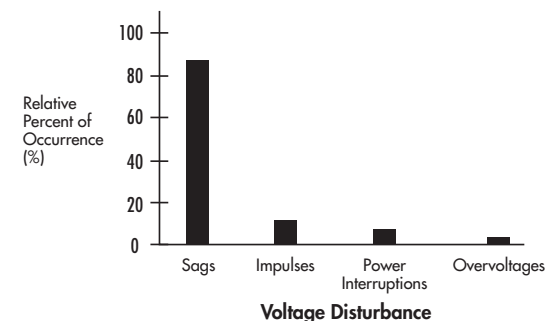

65

**Figure 23: Relative Occurrence of Disturbances to Power Systems Supplying Computers**

Source: Goldstein and Speranza, "The Quality of U.S. Commercial AC Power"; Proceedings of INTELEC Conference, 1982.

In 1991 and 2000, the Canadian Electrical Association undertook major studies of power quality in Canada – the National Power Quality Survey. Utilities from across the country performed monitoring at hundreds of sites. By comparing primary and secondary metered sites, the survey concluded that the average power quality provided by Canadian utilities is very good, and the average quality experienced by customers is good.

There are considerable differences in the state of power quality between sites or locations. This is because of the large number of factors involved, such as customer equipment and wiring practices, the effects of neighbouring customers, geography and weather conditions. Sites that have a small independent power source, or one utility transformer that supplies a number of users, such as strip malls and large buildings, are particularly prone to power quality problems. This is because both disturbing and sensitive loads share the same power supply. In addition, the individual loads can represent a very large proportion of the total amount of electricity supplied to the building, so that changes in voltage can be very significant when one of these loads is turned on or off. Frequently, customers unknowingly cause their own power quality problems by operating disturbance-producing process equipment in the same vicinity as electronic control devices.

From 1992 to 1995, the Electrical Power Research Institute (EPRI) collected data at 300 sites in the U.S. to assess utility power quality at the distribution level. A report\* indicated that sites experienced an average of 9 voltage sag or interruption events per year. In addition, the data indicated that voltage THD (Total Harmonic Distortion) peaked during late afternoon and evening periods. For residential feeders this data is consistent with past experience, since this is where harmonic sources such as television sets are the predominant load on the system.

**Figure 24: Individual Voltage Harmonic Statistics 222 EPRI DPQ Sites from 6/1/93 to 6/1/94**

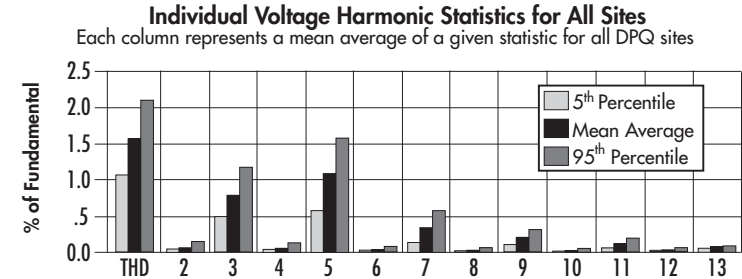

(Reproduced with Permission of EPRI, from \* "Preliminary Results For Eighteen Months of Monitoring from the EPRI Distribution Power Quality Project", D. Sabin, T. Grebe, A. Sundaram, 1994)

## 3.6 Related Topics

### 3.6.1 Electromagnetic Compatibility (EMC)

Electromagnetic compatibility is the term given to the measure and creation of electrical equipment that has both its susceptibility and transmission of electromagnetic noise reduced. The amount of reduction may be regulated by government rule or may be required to meet a certain operational requirement. Areas of EMC that may overlap with power quality are:

- 1) Extremely Low Frequency (ELF) magnetic field interference from power lines (solved by distance, field cancellation or shielding techniques)
- 2) Radiated noise from electronic devices (usually solved with filtering or shielding)
- 3) Radiated noise from power wires (solved with re-routing, shielding or filtering)

- 4) Generation of harmonics by electrical loads (solved with filtering or re-design of the circuitry).

Electromagnetic Compatibility is a more involved and complex subject than can be adequately addressed in this guide. The international technical community has provided standardization activity under the IEC EMC committees (see <http://www.iec.ch/zone/emc> for more information).

## 3.7 Three Power Quality Case Studies

### 3.7.1 Case Study: Meter, Monitor & Manage: A proactive response to power quality

The site in question is located in a multi-story office tower. The top four floors of the building have been designated as a “Business Recovery Center” (BRC) of a large financial institution. The function of the center is to provide backup, mirror and support services for the company’s business units. If a natural or operational disaster occurred, many of the business functions could be temporarily routed to this center. As a result, the BRC contains a significant concentration of computing resources that need to be available at any time. Workstation computing requirements are based on the actual working systems used by line personnel.

Disaster and recovery planning must allow for unforeseen events. Even the best disaster planner will realize that some events contain the seeds for others; some problems are cascading in nature and this requires adaptability on the part of the recovery center. At this location, electrical capacity has been designed to allow for increased loading from extra workstations and servers that may be brought to the site subsequent to the on-set of a recovery situation and added to

the existing complement of business equipment. This could result in system over-loading at some points in the distribution network. In the modern context of loading, harmonic currents need special attention, thus a real time monitoring system was requested to provide harmonic and true loading of the center’s distribution grid.

As was pointed out to the BRC personnel and engineering staff, for only a small additional cost, a total power quality monitoring system could be installed that would provide building envelope information along with distribution point data within the envelope. The BRC utilizes a 600 V base building distribution system. BRC business equipment transformers are fed from one of two bus risers, while mechanical equipment is fed from a separate 600 V bus duct. In the event of a total loss of utility power these bus ducts can be fed by two diesel generators that have an extended operating capability.

The following requirements were developed both from BRC requests and expert input from the various stakeholders:

- Each dry-type transformer in the BRC was to be monitored in order to provide current and harmonic loading, current and voltage distortion, voltage unbalance, and neutral current readings in real time
- Power quality meters to provide transient, sag/swell and waveform deviation graphs and statistics
- Power quality thresholds must be programmable and accessible
- Energy monitoring must provide an aggregated table of consumption criteria with graphs on a monthly basis
- All meters must be fully networked utilizing open standards networking architectures and protocols

One of the key decisions that was made at this site on the basis of data viewed from the power quality component of the meters was with regard to Uninterruptible Power Supplies (UPS). Two issues arose that lead to cost savings. The first of these concerned the need for a large on-site UPS system which was advocated by some. While servers require the ride-through of the UPS, management determined that the impact of transfer switching, while annoying for some is acceptable and that most workstations did not need the protection of 0.5 – 2 s of ride through afforded by the UPS. Data from monthly generator tests revealed however that transfer switch wave shape anomalies were impacting the servers, leading to some network anomalies. The UPSs in use at the site were of a hybrid type that allowed transient and switching noise to pass through the UPS. UPSs were also subjected to excessive battery wear. Based on waveform data captured during testing, a decision was made to switch to an on-line UPS design and to institute a networked UPS management system.

Within 8 months of operation, an increased voltage unbalance was noted on a non-K-rated dry-type transformer. Normally this would indicate a high impedance neutral to ground bond which, if left undetected, would lead to overheating and equipment failure. A check of the meter revealed however that the neutral to ground bond on the meter was loose. Upon tightening this connection the voltage unbalance indication was corrected on the operator display.

This site's experience with the monitoring system has been beneficial in the following ways:

- Data is presented to management that allows new insight into equipment utilization
- Information is available at all times that can define load factors for key processes
- Reporting is available that shows the size, shape and duration of building envelope power quality anomalies.

The money invested in the monitoring system has generated great returns in terms of the impact power quality data has had on equipment purchase and utilization since installation.

### 3.7.2 Case Study: High Demand Load in an Aircraft Assembly Facility

A pulsed laser system used by an aircraft manufacturer was used to number and identify wires on each and every plane manufactured. The unit was malfunctioning and would stop operating for short durations. The cost to the operation involved downtime of staff and equipment but, more importantly, inconsistent wire marking presented a massive safety liability.

The machine operated at 20 Hz supplied from a standard 120 V, 60 Hz single phase branch circuit. The system relied on an effective transfer of peak power from the power supply to the laser. Anything less than the peak power during pulse operations resulted in reduced laser intensity with a consequent lack of quality in the process. Further investigation revealed that the quality of voltage at the site was distorted by 4.5%, and that the peaks of the voltage waveform were flattening out.

A second point of concern occurred when the laser unit was powered up. There was a large current inrush that led to a voltage notch and a drop in peak voltage. This is an impedance interaction: essentially the source is unable to provide the kind of current the load is asking for.

Moving beyond the start-up phase to a period when the laser was being “fired”, the voltage flat-topping was more obvious and the loss of peak voltage was chronic and severe. The peak power delivered to the laser was over 25% less than what was required. Product marking during this cycle was substandard.

Facility electricians were instructed to wire up a temporary source close to the laser load which had a lower impedance and higher capacity. This solution provided a healthier situation for the internal workings of the power supply, since capacitors reach full charge and more power was available for the laser.

72

Why was the capacity of the source increased? Nominally the unit operated on a 20 A breaker at 120 V giving us a rough capacity rating of 2400 VA. The system required large charging currents to power its laser, and therefore a source of 50 A at 120V, 6000 VA, was needed. It is not unusual to have to up-size source requirements considerably for loads of this type.

### 3.7.3 Case Study C: Motor Drive and Transformer Incompatibility in a Commercial Building

This case study looks at a commercial office building which utilizes two banks of AC motors with variable speed drives (VSDs) to control Heating, Ventilating and Air Conditioning (HVAC) functions. Each of the banks is serviced by its own 45 kVA transformer; the only loads on these

transformers are the AC drives. The figure below shows a rather innocuous looking snapshot. The variable speed drives are rather like large switch-mode power supplies which demand peak current after reaching peak voltage.

Power quality experience tells one that a concentration of electronic, single phase loads leads to a 3rd harmonic neutral current. The neutral current in this case is shown in the second figure and can be seen to be primarily composed of 180 Hz. current, peaking above 150 Amps.

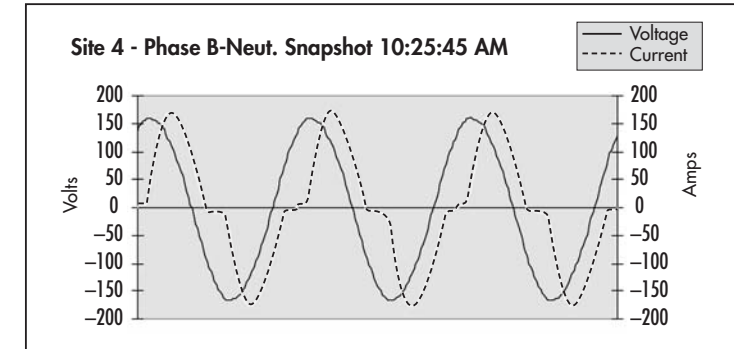

73

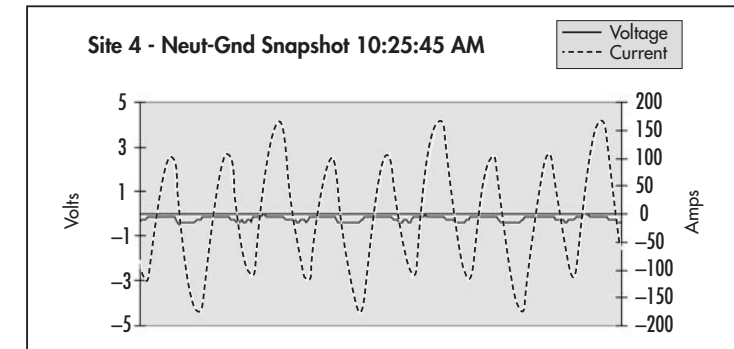

### 3.0 Power Quality Problems

The major problem at this site was the intense heating in the service transformers. The problem became especially acute when tenants on the second floor complained about the smell of smoke from the transformers below them. The transformers were doing a fine job of providing isolation from the third harmonic; the problem was that they were not the right size for the electronic load. In order to provide a complete analysis of a transformer with regard to IEEE 519 harmonics guidelines, some calculations from the name-plate of the transformer needed to be performed.

What was discovered was that the load on the transformers was at least 5 kVA over their nominal de-rated capacity which accounted for the severe heating. Both transformers were operating just above their maximum designed temperatures which will lead to premature insulation failure. What is not shown here, and was required to obtain the results is the raw data analysis from the power quality instrument that obtained the RMS and peak currents.

The solution for this site was new K-rated transformers for each drive bank. Given the isolated nature of the drives and the low neutral to ground voltage, there was no need for phase shifting transformers or special neutral current limiting devices.

### 4.0 Solving and Mitigating Electrical Power Problems

## 4.0 Solving and Mitigating Electrical Power Problems

---

### 4.1 Identifying the Root Cause and Assessing Symptoms

Power quality technologists employ technical instrumentation. This instrumentation can range from simple digital multi-metering through to sophisticated waveform analysis instruments. True power quality monitoring requires full-time monitoring so that steady state effects can be trended and infrequent events can be captured as they occur. A variety of electronic meters are now available for permanent monitoring that offer numerous features at moderate prices.

A trained PQ specialist can also employ a portable instrument, or groups of instruments, to diagnose power quality for fixed periods of time. It should be emphasized that power quality monitoring is a highly technical and potentially dangerous skill; even many trained electricians are completely unfamiliar with the details of how power quality measurement is properly carried out.

**Do not attempt to undertake a power quality measurement exercise without the help of a professional practitioner in the field.**

One of the first things that should be carried out before monitoring begins is a check of the effectiveness, safety and operational characteristics of the wiring in the facility. This will ensure that problems like bad grounding, poor terminations and improperly connected loads are not masking other problems or are, in fact, not mistaken for other types of issues.

## 4.0 Solving and Mitigating Electrical Power Problems

Some of the elements that might be tracked by a PQ professional are:

- RMS (Root - Mean - Square) Measurements
- Average Measurements
- Peak Measurements
- Harmonic Analysis
- Power Line Event Logging

## 4.2 Improving Site Conditions

Consideration of disturbance sources external to the facility should only be considered after the internal electrical environment has been thoroughly checked.

### 4.2.1 Mitigating Effects

The key elements to mitigate power quality problems are:

- proper grounding and wiring
- effective mitigating equipment (if required)

### 4.2.2 Mitigating Equipment

A wide variety of products are available that can help to mitigate power line disturbances. Care should be taken to properly select effective mitigating equipment. Improper application of these products may cause new power quality problems due to unforeseen incompatibilities. Before selecting a product, the customer should have a good understanding of the cause of the problem, as well as the characteristics of the available equipment.

A properly functioning system may be adversely affected by change in the electrical environment, as in a change of load in the facility. Therefore, mitigating equipment that was once

## 4.0 Solving and Mitigating Electrical Power Problems

effective may fail to protect sensitive equipment after such a change has occurred.

When selecting equipment that has an operational heat loss, as indicated by an efficiency rating, provision should be made for adequate cooling of the equipment, especially if it is to be located in a computer room.

### 4.2.1.1 Dedicated Circuits

A dedicated circuit is a single circuit with one load. It is a relatively inexpensive distribution technique that can reduce load interaction. The ability of a dedicated circuit to solve power quality problems depends on its location, impedance, and other factors. To achieve the lowest possible impedance, theoretically, the load of the circuit should be as close as possible to the building service entrance. However, this could aggravate the situation if transients are a problem, since they could travel more freely through the system. For improved operation of the circuit, the neutral and the ground wires should be the same size as the current-carrying conductor.

### Tips and Cautions

Dedicated circuits will solve local problems only. Properly installed dedicated circuits obviate the need for isolated grounding circuits.

### 4.2.1.2 Surge Protective Devices (SPDs; also known as Transient Voltage Surge Suppressors, TVSS)

SPDs are energy diverters that pass the energy contained in a transient to the ground. There are a variety of designs available including gas discharge tubes, line clamps made of semiconducting material, and hybrid designs which may

contain linear inductive or capacitive components. It is important to note that transient suppressors do not provide voltage regulation or isolation.

### 4.2.1.3 Lightning Arresters

The lightning arrester is designed to remove large overvoltages and associated high energy levels. This is accomplished during an overvoltage by short-circuiting the line to ground in what is referred to as a crowbar effect of energy diversion. The conduction of energy to ground will cease when the current drops to zero. The response time for this technology is relatively slow. These products are used as primary arresters on main power feeders.

### 4.2.1.4 End-User SPDs

Faster-acting SPDs that use Metal Oxide Varistors (MOVs), or silicon avalanche diodes (SADs) can be used for lower-voltage transient attenuation. They act by clamping line voltage to a specific value and conducting any excess impulse energy to ground, regardless of frequency. The energy shunting capability of a line clamp is expressed by its joule rating, which determines the amount of energy the device can handle. It is important to realize that these units are only as good as the ground wiring that they are connected to; routing transient energy to ground may result in the mis-operation of some devices. In addition, they are quite susceptible to longer duration overvoltages, which can lead to catastrophic component failure. Silicon avalanche diodes operate on lower voltages, handle less power, but tend to act faster than MOVs, and are often used in communication systems for these reasons. Due to the clamping nature of a surge suppressor, it cannot remove voltage irregularities that

occur within the sine wave envelope but do not exceed the limiting threshold.

**Figure 25: Effect of Line Clamp on Transient Voltages, 120 Volt System**

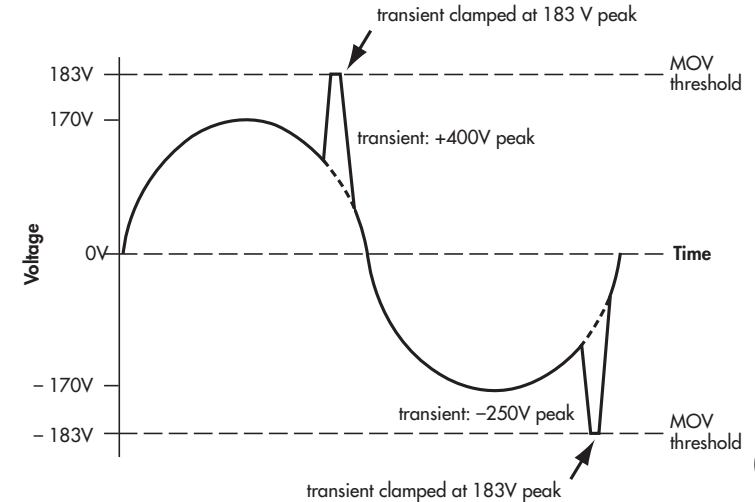

**Figure 26: Example of Impulses Not Clamped**

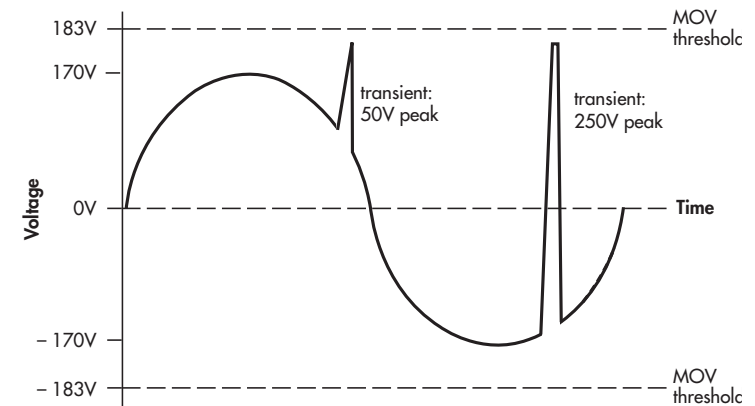

### 4.2.1.5 Power Line Filters

Filter design is a complex topic and needs to be properly addressed by a qualified power quality practitioner.

#### Linear Passive Filter

##### Design and Operation

A linear filter is composed of linear components, such as inductors and capacitors. It passes the basic power frequency (60 Hz) and attenuates other frequencies which are in the form of electrical noise and harmonics.

Some filters are tuned circuits, which means they address a small range of frequencies. Examples of filters that are not tuned are the simple low pass filter, and the simple high pass filter (next page).

##### Uses

Simple low pass filters attenuate high frequencies, and have the general characteristics most desired in filters for improved power quality and noise attenuation.

Simple high pass filters attenuate low frequencies.

Tuned shunt filters are not used for general power quality applications.

Special designs are used to attenuate harmonics. A shunt connected tuned filter, which consists of an inductor, a capacitor and a resistor, is tuned to eliminate a specific harmonic order by providing a low impedance to the harmonic frequency and shunting the harmonic energy to ground. A number of these filters may be arranged in stages, with each stage selectively filtering a given harmonic frequency.

**Figure 27: Examples of Untuned Filters**

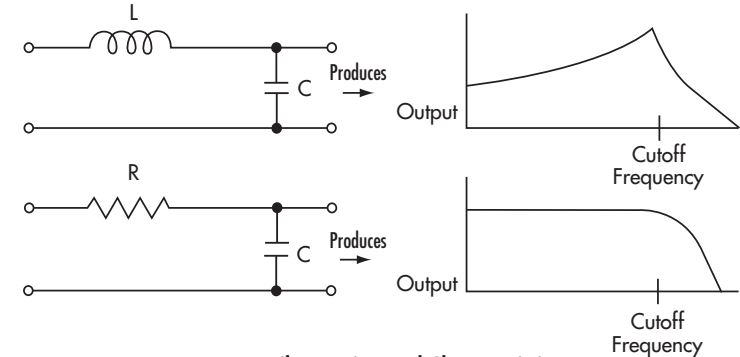

**Low Pass Filter Design and Characteristics**

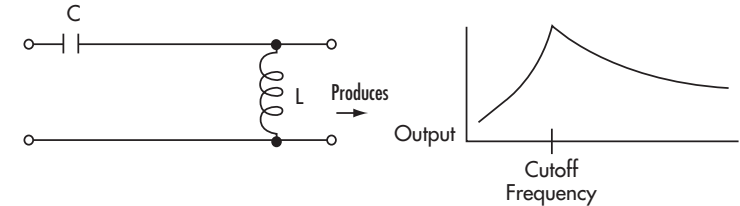

**High Pass Filter Design and Characteristics**

### *Examples of Harmonic Filters*

Equipment which is either sensitive to electrical noise, or which creates it, is often designed with linear filters for protection of equipment. For instance, all power supplies contain electrical filters. For harmonics, multi-staged shunt filters are most effective for mitigation of lower order harmonics.

### *Disadvantages*

- Common mode noise is not necessarily eliminated by the use of linear filters.
- Low pass series filters are seldom used for harmonic attenuation since they must be rated for full line current making them relatively expensive.
- Shunt filters applied at individual loads can often be overloaded by harmonics produced by nearby loads or even at other customer sites.

#### 4.2.1.6 Isolation Transformers

### **Design and Operation**

Isolation transformers consist of two coils (primary and secondary) intentionally coupled together, on a magnetic core.

They have two primary functions:

- a) They provide isolation between two circuits, by converting electrical energy to magnetic energy and back to electrical energy, thus acting as a new power source.
- b) They provide a level of common mode shielding between two circuits.

Since the ability of a transformer to pass high frequency noise varies directly with capacitance, isolation transformers should be designed to minimize the coupling capacitance between primary and secondary sides, while increasing the coupling to ground. Isolation transformers have no direct current path between primary and secondary windings. This feature is not characteristic of an auto-transformer, and therefore an auto-transformer cannot be used as an isolation transformer.

Unshielded isolation transformers can only attenuate low frequency common mode noise.

High frequency normal mode noise can be attenuated by specially designed and shielded isolation transformers, although it is not frequently required (consult with your electrical system expert).

### *Advantages*

- Isolation transformers are used to attenuate common mode noise.
- They provide a new neutral to ground reference point.
- They can be used to break ground loops.
- Isolation transformers can reduce higher order harmonics, but will not eliminate harmonic distortion or prevent notching.
- Isolation transformers may be combined with other equipment such as transient suppressors and circuit breakers to form complex circuits known as Power Distribution Units (PDUs).
- Only high quality shielded isolation transformers should be used in critical applications.

### *Disadvantages*

- No voltage regulation or ride-through capabilities are available.
- Poorly designed isolation transformers may produce harmonics.
- The ability of an enhanced isolation transformer to attenuate normal mode noise varies, depending on the load.

#### 4.2.1.7 Line Voltage Regulators

### **Design and Operation**

A line voltage regulator is a device that maintains a relatively constant voltage output within a specified range, regardless of input voltage variations. Some kinds of line voltage regulators can regulate, but not “condition”, the power. They are less frequently used, and include the ferroresonant transformer, the tap switching transformer, the variable ratio transformer, the magnetically coupled voltage regulator, the induction regulator and the saturable reactor. The ferroresonant transformer and tap switcher are discussed in more detail within this section.

Auto-transformers are frequently used in voltage regulation devices. If an auto-transformer is used as the variable circuit element, it develops a variable voltage which is added to the incoming AC line voltage. A sample of the input voltage is rectified, filtered and compared to a DC reference voltage. The difference is then used to offset the input voltage change. Auto-transformers are also used in Silicon Controlled Rectifier regulators. In this case, the primary voltage of the autotransformer is varied by phase control.

### *Uses*

These products regulate voltage to protect against momentary and transient disturbances, within a certain range. Their response time is typically one cycle.

Regulators are already built into some sensitive equipment. Most regulators that are built into equipment, however, are DC regulators.

### *Disadvantages*

- Voltage regulators do not have noise suppression capabilities.
- Those with switching power supplies actually create noise in the input line.

#### 4.2.1.8 Ferroresonant Transformers

In contrast to a typical isolation transformer, the ferroresonant transformer is designed to operate at saturation. The ferroresonant transformer provides the same functions as the shielded isolation transformer, but also provides instantaneous, continual voltage regulation, as well as ride-through capabilities.

A ferroresonant transformer has a relatively simple design, and no moving parts; however this mitigation device was designed for older, linear electrical loads. A ferroresonant transformer is often incompatible with modern electronic loads and should be used with caution on high demand loads. Ferroresonant transformers usually have higher operating temperatures that can lead to very warm equipment enclosure temperatures. It is therefore recommended that these transformers be safely guarded from accidental contact by personnel.

### 4.2.1.9 Tap Switching Transformers

#### **Design and Operation**

An electronic tap switching transformer, or tap switcher, regulates output voltage by changing the ratio of primary windings to secondary windings in response to fluctuations in input voltage or load. This is accomplished with solid state switches (SCRs or TRIACS) which select the appropriate taps to compensate for the fluctuations. Voltage is regulated not continuously, but in steps. Switching occurs when line voltage passes through zero, so transients are not created.

- The tap switcher can react in one or two cycles.
- Either peak or RMS voltage detectors may be used.
- Taps may either be on the primary or secondary side.

#### *Uses*

Where voltage fluctuation is the primary concern.

#### *Disadvantages*

Voltage output changes are not continuous. Better voltage continuity is achieved by using more taps.

If auto-transformers are used, no isolation is provided.

### 4.2.1.10 Power Conditioners

Devices marketed as power conditioners are often combinations of the above-mentioned mitigation devices. They often contain transient voltage surge suppression, noise filters, and isolation transformers or voltage regulators. Careful consideration of product specifications and the intended use are required in order to determine if they will be effective.

### 4.2.1.11 UPS Systems

“UPS” means uninterruptible power supply. A UPS system contains a component that stores energy which can be used during power interruptions. UPSs are available in a wide range, from basic battery backup to units that can supply power for days.

UPS systems can be on-line or off-line (standby). Typically, the on-line systems provide greater protection and cost more. These systems may be either rotary or static. Rotary systems employ rotating machines; static systems use solid state components. A UPS does not necessarily provide protection against high energy impulses.

A properly selected UPS system is the only product, other than a generating unit, that can protect critical loads against power interruptions exceeding 0.5 seconds and which can provide active regulated power.

Some inexpensive UPS systems with low power ratings produce a square wave output, causing some loads to malfunction. This characteristic is particularly true for standby UPS systems. The problem can be avoided by selecting a UPS system with a synthesized sine wave.

Disagreement often arises as to the preferred type of system, rotary or static. Rotary systems are often criticized for the regular maintenance they require, whereas static systems are criticized for the frequency of failed components. It should be pointed out that regular maintenance and parts replacement of rotary systems helps to prevent component failures, whereas static systems can run for a significant period of time without maintenance before failure with minimal downtime. No matter what system is selected, the user should expect that some type of maintenance or

replacement will eventually be required. Multiple UPS systems can be used for redundancy in critical applications. They can be arranged in parallel, in which case they normally share loads, or in isolation, so that each UPS supplies a specific load under normal operation.

Large UPS systems (>100 kVA) typically employ inverters and wet-cell batteries, which require ventilation. Care should be taken to locate these items in protected, ventilated areas. Regardless of where the system is situated, the room should be relatively free of dust, and the temperature maintained near 25°C for optimum battery life and performance. More recently designed small UPS systems (<100 kVA) employ sealed batteries, which emit no hydrogen gas, and transistorized inverters, which are very quiet. The batteries are mounted in a cabinet, and the whole system can be placed in a computer room. Care should be taken to ensure that adequate battery life is available for these systems.

### Battery Design and Selection

A battery is an electrochemical device that converts stored chemical energy into electrical energy.

Recharge time is typically 8-10 times the discharge time. When selecting a UPS battery, the cell size, cell life, required voltage, reliability, weight/space and manufacturer's warranty should be considered. It is also important to note that battery discharge time as a function of load is not a linear relationship. Two basic types of batteries that are used for UPS systems are lead acid and Valve Regulated Lead Acid (VRLA). Carefully consider the minimum amount of battery time that is necessary in order to reduce capital and maintenance costs in the system.

### Rotary UPS

A state-of-the-art, on-line rotary UPS is one of the most effective but more costly types of UPS systems. Although a number of designs are available, they include motor-generators with battery backups and fly-wheel systems.

#### 4.2.1.12 Isolated Grounding Outlets

An isolated ground (IG) outlet as recognized by Electrical Codes is a receptacle, orange in colour or with an orange triangle and marked "Isolated Ground", that is wired as an individual branch circuit outlet. This outlet has a separate green or green/yellow wire along with the normal uninsulated ground wire that runs continuously from the ground conductor terminal to the first panelboard where it is connected to the ground bus. Bonding of the conduit, boxes, etc. of the circuit is accomplished by ordinary means, i.e., conduit or a separate ground wire. The two grounds are connected only at the panelboard.

Many years ago, this arrangement was implemented to reduce common-mode noise problems. Common-mode noise is better attenuated at each device in the system and is in fact effectively filtered at the input of modern electronic devices.

The IEEE Emerald Book states that:

*"This type of equipment grounding configuration is only intended to be used for reducing common-mode electrical noise on the electronic load equipment circuit as described in the NEC. It has no other purpose and its effects are variable and controversial."*

Isolated grounding receptacles are no longer recommended for installation in any situation. The effects they are supposed to solve can be more easily and cheaply mitigated with robust electrical system design.

### 4.2.3 Preventative Measures

#### 4.2.3.1 Distribution System Considerations for Sensitive Loads

The quality of the power supplying sensitive loads is very heavily influenced by other loads within a customer's facility. If there are "heavy" loads such as motors or heating, ventilating and air conditioning systems being supplied, voltage drops and electrical noise can be generated causing power quality problems for sensitive loads such as computer loads.

As an illustration, consider the following distribution system supplying both motor loads and sensitive electronic loads. In this case the sensitive loads are fed from phase to neutral, and motors are fed phase to phase.

**Figure 28: Motor and Sensitive Loads Supplied from the Same Feeder**

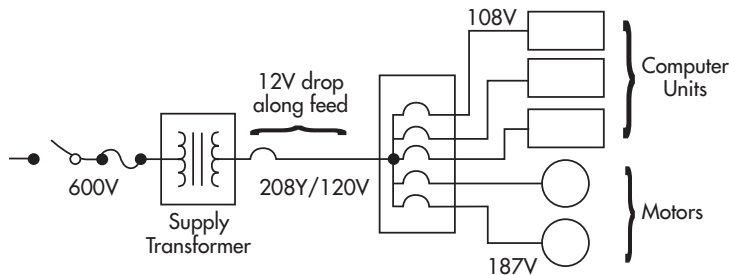

If the feeder has a resistance of 0.075 ohms, during a motor start the voltage drop along the feeder is:

$$\begin{aligned} V &= IR \\ &= 160A \times 0.075\Omega \\ &= 12V \end{aligned}$$

Voltage at the sensitive loads is 120 - 12 = 108V

Voltage at the motors is 208 - ( $\sqrt{3} \times 12$ ) = 187V

If the motor is a 10 HP motor, it will draw an inrush current in the order of 160 A for a short period of time when starting.

The impedance of the feeders to the distribution panel supplying the motor and sensitive loads will cause a voltage drop of 12 volts or more while the motor is starting. Because of this voltage drop the sensitive loads will be supplied with only 108 volts for a short period of time. Unless the sensitive loads have an adequate amount of stored energy to *ride-through* the voltage sag, they may malfunction. In addition, the current drawn for the first one or two cycles of the motor start, while the stator is magnetizing, is 2 to 3 times higher than the normal starting current. This will lead to only 84 V feeding the sensitive loads during this time.

**If the motor load and the sensitive loads are supplied from separate feeders then the voltage drop does not occur in the feeder supplying the sensitive loads.**

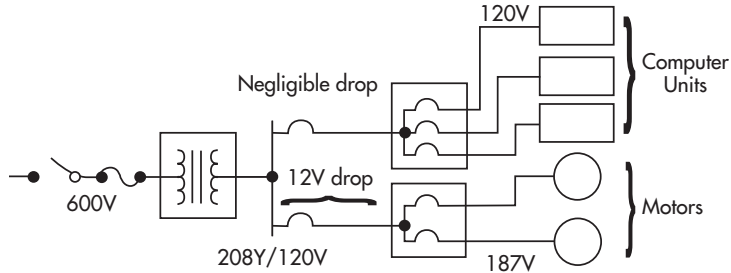
**Figure 29: Motor and Computer Loads Supplied from Separate Feeder**

An even better approach is to effectively create a new supply system for the sensitive loads by using a transformer in addition to a separate feeder

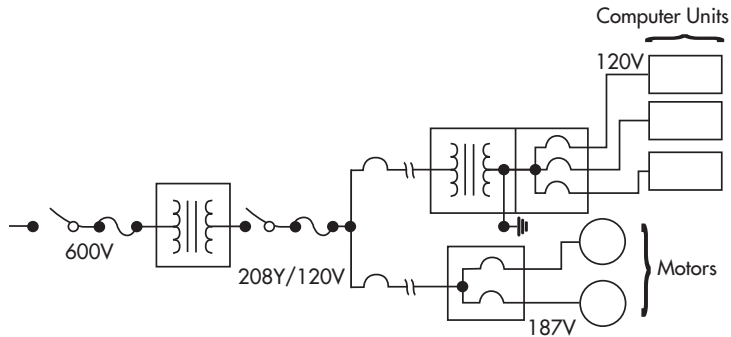
**Figure 30: Isolation Transformer Added to Computer Feeder Supply**

A transformer establishes a separately derived power source. The transformer can be of the step-down type to reduce the supply voltage to the utilization voltage of the equipment or an isolation transformer if the supply voltage is already at the appropriate voltage.

Typical voltages for computer equipment are 120 volts single phase and 120/208 volts three-phase wye. **If the sensitive loads are susceptible to some form of RFI (radio frequency interference), the transformer may utilize a shield that isolates electrical and magnetic noise coupling from the primary to the secondary of the transformer. This shield is connected to ground.** The neutral on the secondary of the transformer must be connected to ground per the applicable Code in your jurisdiction.

#### 4.2.4 High Frequency Grounding Considerations

Equipment grounding and the grounding of the electrical distribution system provide a low impedance path to ground for low frequencies (mainly 60 Hz and up to the 11th harmonic). Computers and microprocessor controlled equipment operate at high frequencies (in the 100s of MHz for control devices and well into the GHz region for IT and communications equipment).

IT equipment transfers data between various pieces of equipment at very high frequencies utilizing low signal levels. In the past, where these signal levels were referenced to the local ground system, they were susceptible to electrical noise and interference. Examples of the types of interfaces that suffered from noise coupling problems were the RS-232 interface and the Centronics printer interface. Grounded interconnection standards like these have been largely superseded by isolated and higher speed connections like Ethernet, fibre optics and USB. *Where older analog communications systems and digital interface standards are still used, these types of equipment need an effective means of grounding for both low and high frequencies. A more effective approach is to eliminate all ground-referenced communication interfaces in a facility with newer, higher speed and noise immune interfaces.*

### Effects of Frequency on Conductors

Wiring systems used within a building generally have low impedance at low frequency, but as the frequency increases the impedance increases. “Real” wiring can be modeled by a wire with resistance and inductance and stray capacitance to ground distributed along its length.

For a grounding conductor to be effective at high frequencies it must be short to minimize the effects of stray capacitance and distributed inductance along its length. A rule of thumb is that the conductor should be shorter than 1/20th of the wavelength at that frequency. This means a length shorter than 1.4 m at 10 MHz. The single point, parallel path ground, which makes for a good equipment ground, is a less reliable high frequency signal ground.

In order to satisfy both equipment grounding and signal grounding requirements, a hybrid system should be employed. This system is a combination of the parallel path ground combined with a multipoint ground for good high frequency performance.

One such method, described in IEEE 1100-1999, The Emerald Book, is a signal reference structure.

**Figure 31: Equivalent Circuit of a Wire**

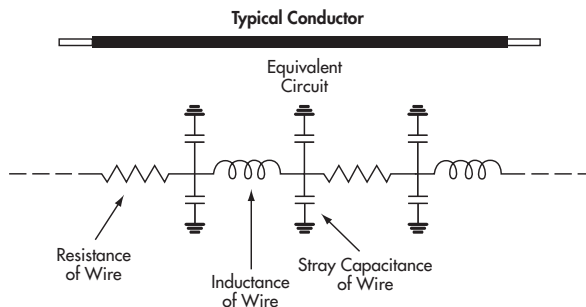

### Signal Reference Structure

A ground plane is a conducting surface that has low impedance over a range of frequencies. The ideal situation would be to have all communications equipment located on a ground plane so that short connections could be made from the equipment to the plane.

While it is usually not practical to have a true ground plane, an effective alternative is a grid of conductors spaced on regular intervals, bonded at their intersections on the subfloor of a room’s raised floor, where it exists. This is called a Signal Reference Grid (SRG). In the absence of a raised floor, the bonded interconnection of equipment racks and trays at regular intervals also creates a SRG effect.

**Figure 32: Signal Reference Structure or “Grid”**

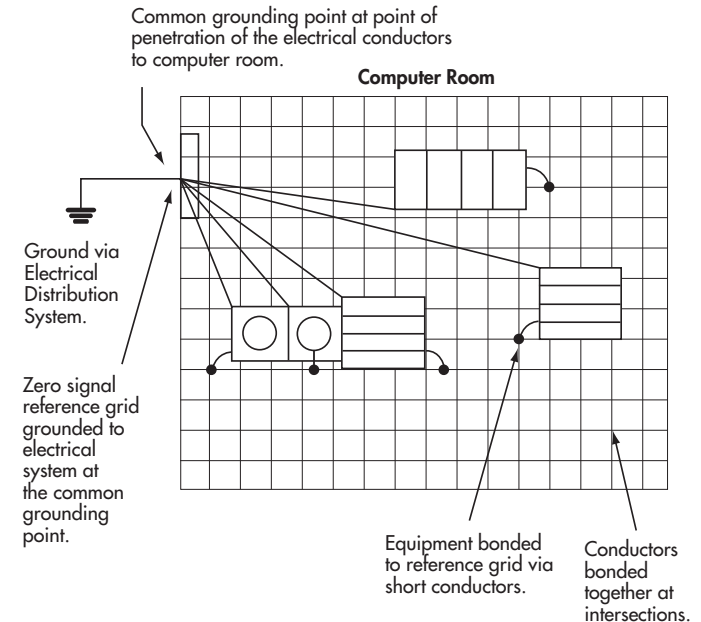

## 4.0 Solving and Mitigating Electrical Power Problems

The grid is grounded to the electrical system ground at the point where the supply enters the room. All powered equipment is also grounded at this point making the equipment grounding a single point system.

Equipment is bonded to the reference grid via short conductors creating a low impedance path to ground for high frequencies. This hybrid system satisfies both equipment and high frequency grounding requirements and complies with the Electrical Safety Code. It creates a more stable and robust environment for all equipment connected to it in the event of a voltage transient or system fault impacting the electrical system.

## 4.3 Troubleshooting and Predictive Tips

### 4.3.1 Tips

#### Distribution Wiring and Grounding

- Check that the electrical contractor is reputable, and practices proper grounding and wiring techniques. The electrical installation should be tested with instruments to determine compliance to Codes and equipment requirements. Have all wiring inspected.
- Electrically separate highly sensitive loads from other loads. This may involve using separate buses, or separate distribution transformers. The Code generally does not allow separate AC services to be used in a facility.
- Ensure that all equipment is CSA certified for safety reasons. Before purchasing mitigating equipment, ensure that all distribution and grounding problems

## 4.0 Solving and Mitigating Electrical Power Problems

have been identified and corrected. Then identify any problems that require mitigating equipment.

- Ensure that all components of interconnected IT equipment are bonded to the same grounding system.
- For the purposes of signal grounding, never assume that two physically separated points of a ground system will be at the same potential. Use isolation techniques or current transmitters for physically separated equipment.
- If significant changes have been made in an electrical system, and a low voltage condition exists, notify the utility.

#### Mitigating Equipment

- Ensure that overvoltage protection exists at the powerline entrance to the building and at other susceptible points.
- When purchasing electrical products, ensure that they will effectively perform the functions that are required, and cause minimal degradation of the power system. It is a good idea to request a demonstration of the equipment within the plant, when possible, especially for mitigating equipment.
- Following installation of mitigating equipment, verify that the problem is solved.
- Always identify any equipment sensitivity requirements, such as sensitivity to voltage fluctuations, in specifications.
- Consider the interaction between mitigating equipment and the load. For instance, if the mitigating equipment has a high impedance, and the load has high inrush current (due, perhaps, to the starting of large motors), a

voltage sag could result

- The noise suppression capabilities of some products may be specified in terms of peak attenuation, which may not be appropriate for some applications. In addition, it is important to know the conditions under which the attenuation was measured.
- Proper installation of electrical equipment is very important and yet often overlooked. For example, many ferroresonant transformers and power conditioners are improperly installed due to incorrectly sized primary conductors or breakers.

### Equipment Ratings

- The purchaser should check if quoted equipment capabilities apply to units operating at no load, partial load or full load.
- All electrical equipment should be properly sized. Products may be sized by power, in volt amps (VA), or by maximum current rating in amps. To determine proper sizing, the following steps should be taken:
  - Determine the load operating voltage, current, and/or VA from the nameplate rating.
  - Sum all individual VA ratings of the loads. To obtain an estimate of the power consumed by the load, which is the real power in watts, calculate:  
Real Power = VA x Power Factor.
  - Many nameplate ratings assume a power factor of unity. If this is not a good assumption, factor this in. Some units are rated in Primary Power ratings. If this is the case then the sum of all secondary loads will have to be divided by the efficiency of the unit in order to obtain the Primary Power

rating. It is especially important to obtain the power requirements for sensitive loads from the manufacturer.

### Best Practices

- Reduce the number of disturbance sources.
- Maintain a malfunction log.
- Customers should be aware of the level of harmonics they are producing. If a customer is exceeding the acceptable limits of the distribution system, they may be required to shut down their facility.
- To minimize problems related to voltage sags use reduced voltage starters on motors
- If installing an isolation transformer, ensure that the ground on the secondary side is properly connected.
- Above all, know and understand the technology of mitigating equipment before applying it.

### 4.3.2 Troubleshooting

If an electrical end-user suspects that a power quality problem exists in his facility, there are a number of steps that may be taken to troubleshoot the problem. The key is a process of elimination. Reputable consultants may be contacted by the customer to assist the process:

1. Define the type of disturbance, frequency of occurrence and magnitude of the problem.
2. Determine which power conductors -- hot, neutral or ground -- have problems; this is critical, since some mitigation techniques only address problems with a specific conductor. For grounding problems, the source of the problem must be fixed; no mitigating equipment

will provide a solution.

3. Check wiring for loose connections.
4. Check that proposed solutions actually work and follow-up.

# 5.0 Where to Go for Help

---

## Web Resources

### IEEE Standards Information

Home of the IEEE standards; in particular 446; 519; 1100 (“The Emerald Book”, considered the key IEEE reference on power quality); 1159; 1250 and 1346.

### Copper.org

A site by the Copper Development Organization responsible for promoting the use of copper; check out the reference primer on power quality.

### Power Standards Laboratory

A web site from principal, Alex McEachern, about voltage sags.

### Underwriters Laboratories, Inc.

A good power quality reference is UL Standard 1449, second edition that describes performance specifications for surge protection devices.

### Power Quality Guidelines for Energy Efficient Device Application

This guidebook has three primary objectives:

- 1) to improve guidelines for minimizing any undesirable power quality impacts of energy saving technologies,

- 2) to provide an understanding of the energy savings potential of power quality related technologies and
- 3) to provide guidelines for evaluating “black box” technologies.

#### Semiconductor Equipment Materials International

SEMI F47, Specification for Semiconductor Processing Equipment Voltage Sag Immunity, is available from SEMI.

#### International SEMATECH Technology Transfers

This web site is by Sematech, a consortium of semiconductor manufacturers and tool manufacturers. It contains the report, “Guide for the Design of Semiconductor Equipment to Meet Voltage Sag Immunity Standards.”

#### IEC Standards Information

Information about types of disturbance, emission and immunity, etc., as well as the different IEC Standards can be found at: <http://www.iec.ch/zone/emc/whatis.htm>

#### National Fire Protection Association

Information about electrical safety can be found at: <http://www.nfpa.org>

### CSA Relevant Standards

Standards are available at:

<http://www.csa-intl.org/onlinestore/GetCatalogDrillDown.asp?Parent=183>

- CAN/CSA-C61000-2-2-04  
Electromagnetic Compatibility (EMC) - Part 2-2: Environment - Compatibility Levels for Low-Frequency Conducted Disturbances and Signaling in Public Low-Voltage Power Supply Systems”
- CAN/CSA-CEI/IEC 61000-2-8-04  
Electromagnetic Compatibility (EMC) - Part 2-8: Environment - Voltage Dips and Short Interruptions on Public Electric Power Supply Systems with Statistical Measurement Results
- CAN/CSA-C61000-3-3-06  
Electromagnetic Compatibility (EMC) - Part 3-3: Limits - Limitation of Voltage Changes, Voltage Fluctuations and Flicker in Public Low-Voltage Supply Systems, for Equipment with Rated Current  $\leq 16$  A per Phase and Not Subject to Conditional Connection
- CAN/CSA C61000-3-6-04  
Electromagnetic Compatibility (EMC) - Part 3: Limits - Section 6: Assessment of Emission Limits for Distorting Loads in MV and HV Power Systems - Basic EMC Publication
- CAN/CSA-C61000-3-7-04  
Electromagnetic Compatibility (EMC) - Part 3: Limits - Section 7: Assessment of Emission Limits for Fluctuating Loads in MV and HV Power Systems - Basic EMC Publication
- CAN/CSA-CEI/IEC 61000-4-11-05  
Electromagnetic Compatibility (EMC) - Part 4-11: Testing and Measurement Techniques - Voltage Dips, Short Interruptions and Voltage Variations Immunity Tests

- CAN/CSA-CEI/IEC 61000-4-34-06  
Electromagnetic Compatibility (EMC) - Part 4-34:  
Testing and Measurement Techniques - Voltage Dips,  
Short Interruptions and Voltage Variations Immunity  
Tests for Equipment with Input Current More Than  
16 A per Phase
- CAN/CSA-C61000-3-11-06  
Electromagnetic Compatibility (EMC) - Part 3-11:  
Limits - Limitation of Voltage Changes, Voltage  
Fluctuations and Flicker in Public Low-Voltage Supply  
Systems - Equipment with Rated Current  $\leq 75$  A and  
Subject to Conditional Connection

- T004700 5108  
Techniques to Assess Harmonic Distortions for  
Systems with Distributed Harmonic Sources

## CEATI Reference Documents

- T984700 5103  
Canadian Power Quality Survey 2000
- T034700 5120  
Review of Flicker Measurement of the CEA DPQ  
Survey 2000
- T014700 5113  
Sag, Swell and Short Interruption Evaluation from the  
Canada PQ Survey 2000
- T044700 5123  
Power Quality Impact Assessment of Distributed Wind  
Generation
- T044700 5126  
Customer Power Factor Correction Capacitor  
Application Guide
- T014700 5110  
An Automated Method for Assessment of Harmonics  
From Non-Linear Loads and Distributed Generators

Notes:

Your feedback and comments are appreciated. Please provide feedback to [info@ceatech.ca](mailto:info@ceatech.ca)

## Energy Efficiency is Good Business

- Economic Prosperity
- Environmental Performance
- Social Responsibility
- Security